

Supermarket Compression

Education You Can Build On

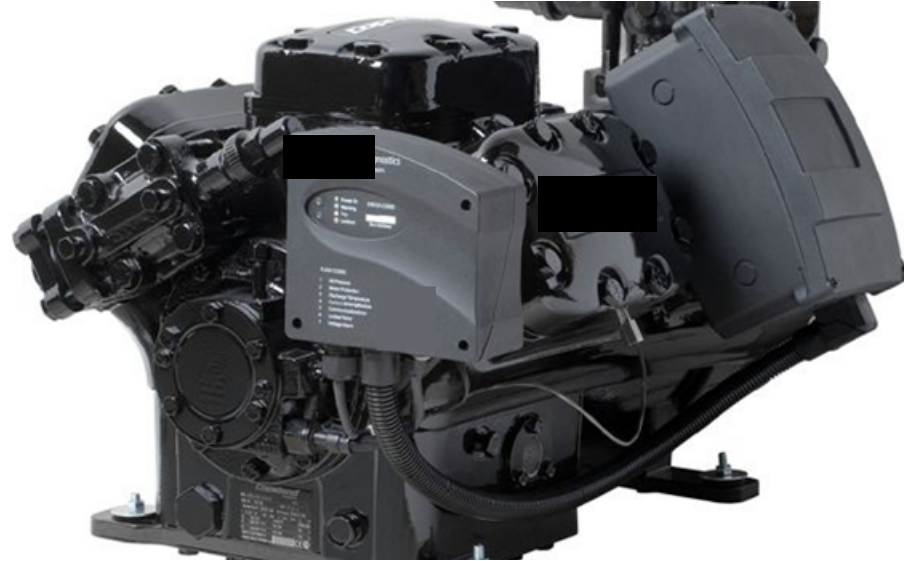

Ed Seffens: Senior Account Executive
Emerson Climate Technologies

Does The Thing Work?

Did You Mess With It Anyway?

Did You Mess With It?

Does Anyone Know?

You Dummy

You're Out Of Luck

Hide It

Can You Blame Someone Else?

Will You Be In Trouble?

NO PROBLEM!

Forget About It

Don't Mess With It!

YES

NO

NO

YES

YES

NO

NO

YES

YES

NO

NO PROBLEM!

Forget About It

Don't Mess With It!

Does Anyone Know?

You're Out Of Luck

Hide It

Can You Blame Someone Else?

Will You Be In Trouble?

NO PROBLEM!

Forget About It

Does The Thing Work?

Did You Mess With It Anyway?

Did You Mess With It?

Does Anyone Know?

You Dummy

You're Out Of Luck

Hide It

Can You Blame Someone Else?

Will You Be In Trouble?

NO PROBLEM!

Forget About It

Don't Mess With It!

YES

NO

NO

YES

YES

NO

NO

YES

YES

NO

NO PROBLEM!

Forget About It



Supermarket Refrigeration

Education You Can Build On

Traditional Multi-Plex System

- Medium and Low Temp Rack Systems
 - 2 to 5 Compressors per system
 - Low Pressure Oil Distribution
 - Compressors Cycling On/Off to match load
 - Lead Compressor might have unloading
 - 3D Moduload?
 - Energy Inefficient

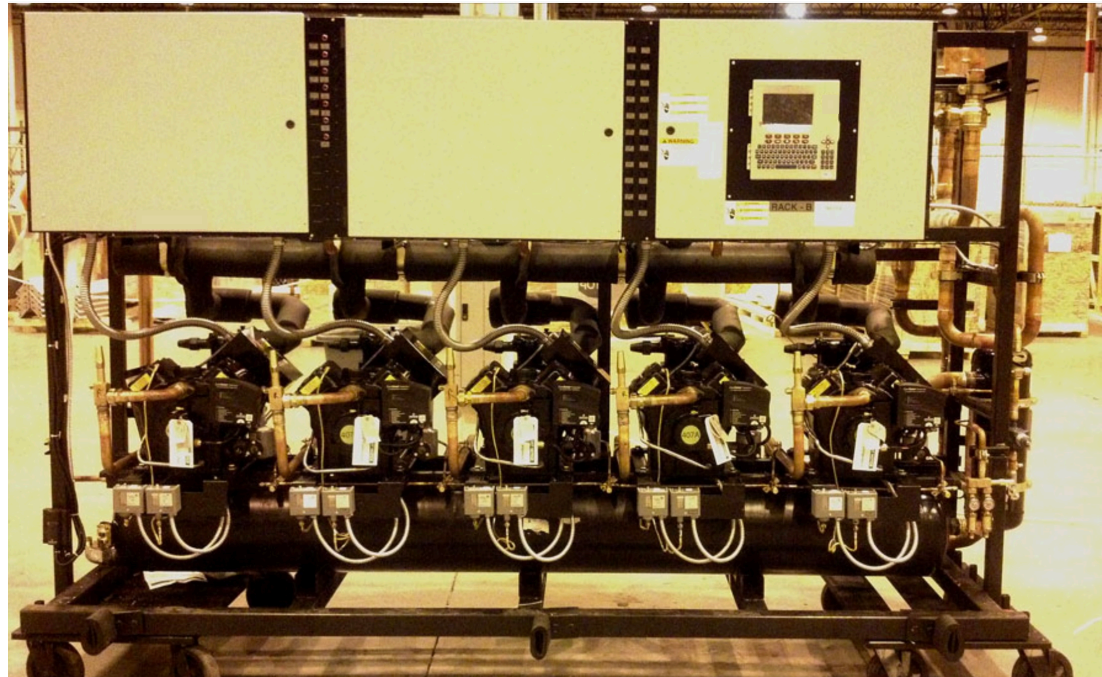



Digital Technology- Theory and Operation

Education You Can Build On

Capacity Modulation Capabilities

	Inverter 50-100%	Blocked Suction 50% or 100%	Continuous Capacity Control\
Recip	✓	✓	✓ 10-100%
Scroll	✓		✓ 10-100%
Screw	✓		✓ 25-100%



Discus
w/ Blocked Suction



Scroll™
Digital



Discus™
Digital

What Is Digital?

- Digital Technology Is Fundamentally Different From The Traditional Inverter Technology.
- The Capacity Modulation Of The Digital Compressor Is Achieved By The Time Averaging Of A “Loaded State” And “Unloaded State”.
- It Is Unique, Reliable And Very Simple To Apply.

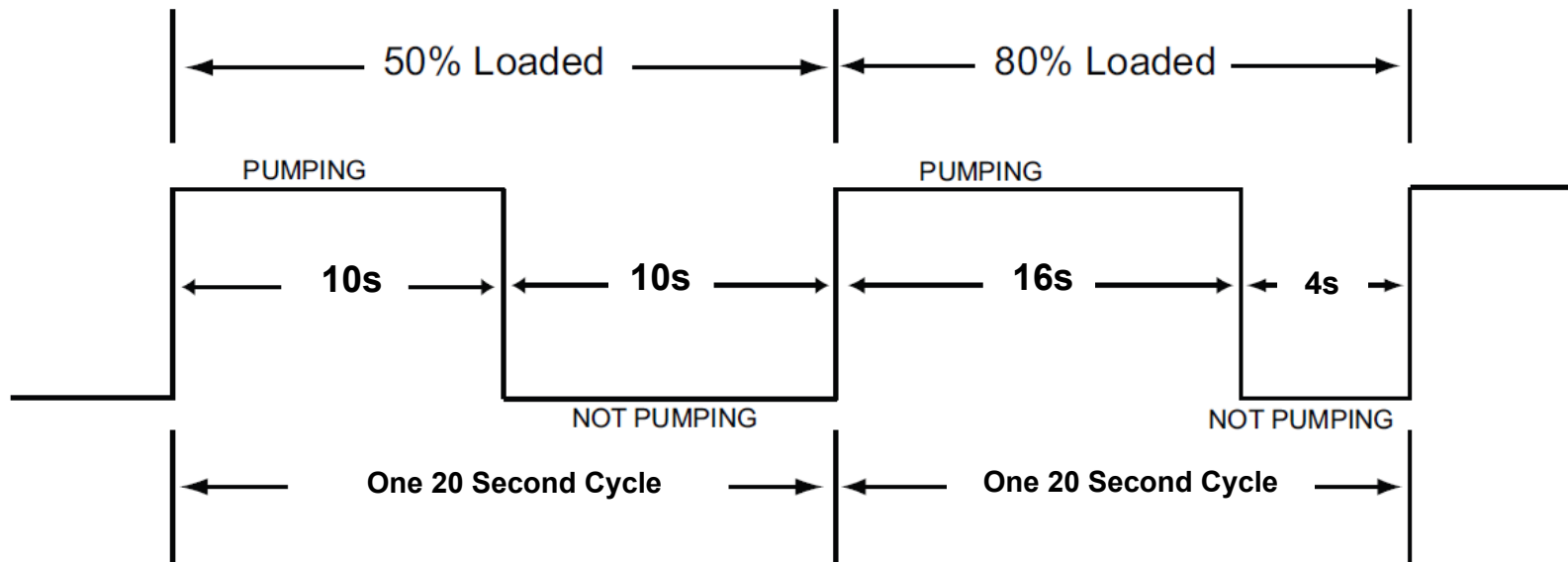

Digital Scroll Compressor For Refrigeration

- Scroll That Is Capable Of Capacity Modulation
- Modulation Range From 10% - 100%
- Approved For High, Medium & Low Temperature Applications In R404A
- Currently 4 & 6-HP High/Medium & 6-HP Low Temperature



Pictorial Only

Digital Scroll Compressor Nomenclature

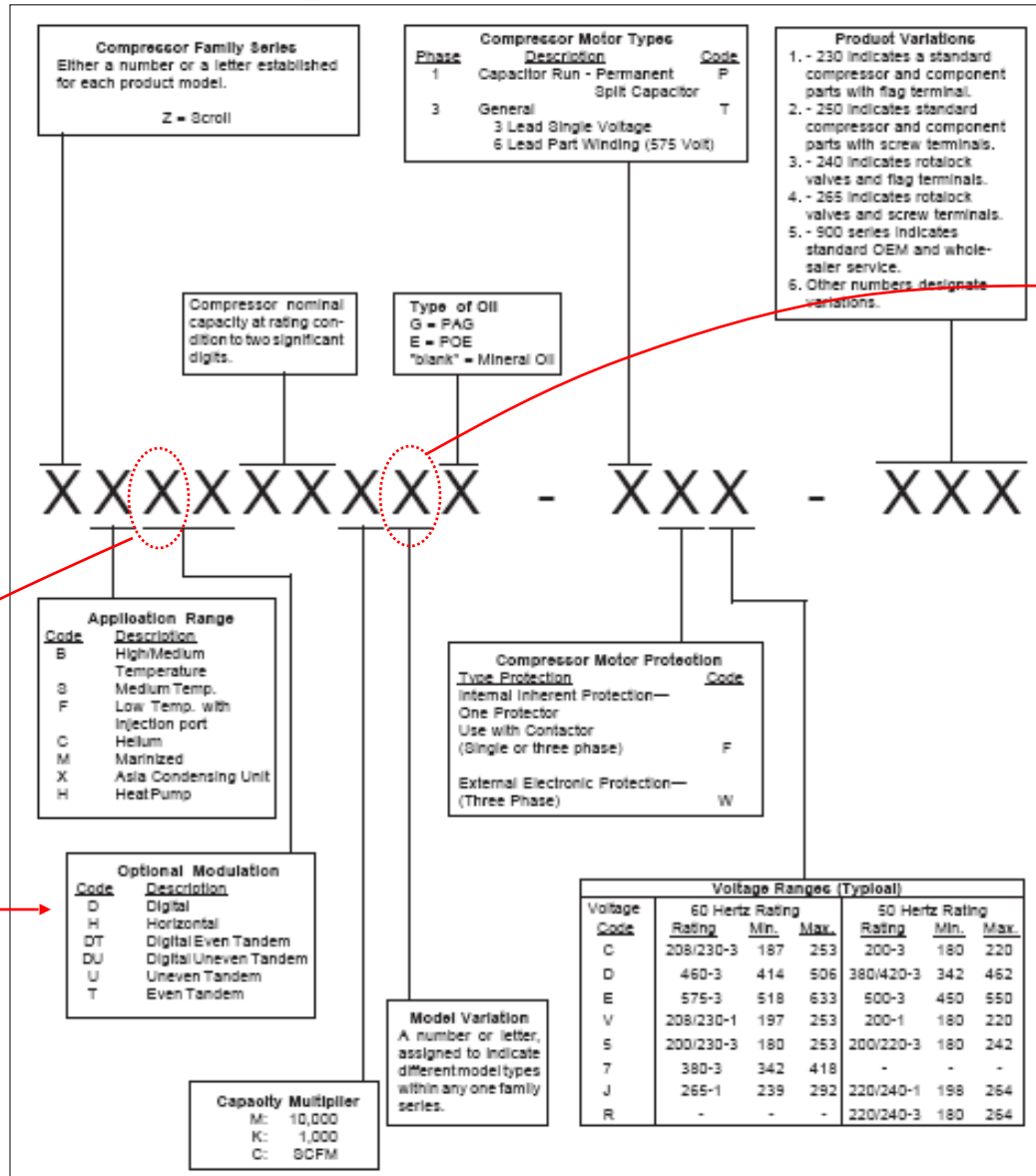

This Letter Is "V" For Vapor Injected

Third Letter Is "D" For Digital

Compliant Scrolls

Axial Compliance

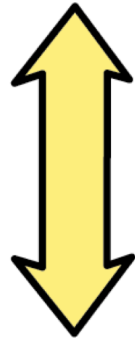
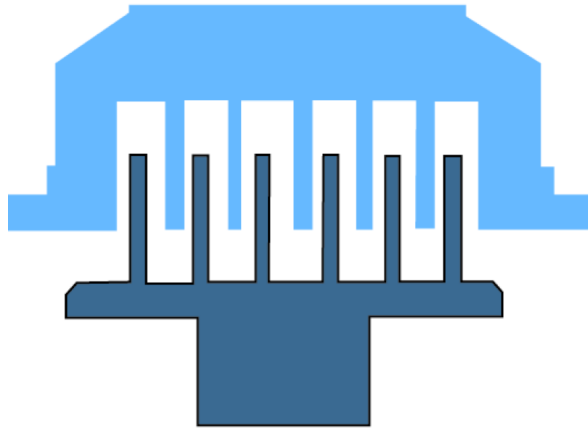

Radial Compliance

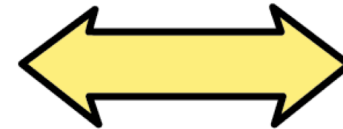
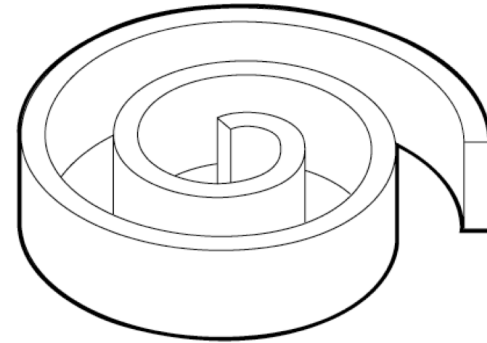

Compliance => Reliability + Performance

Axial Compliance

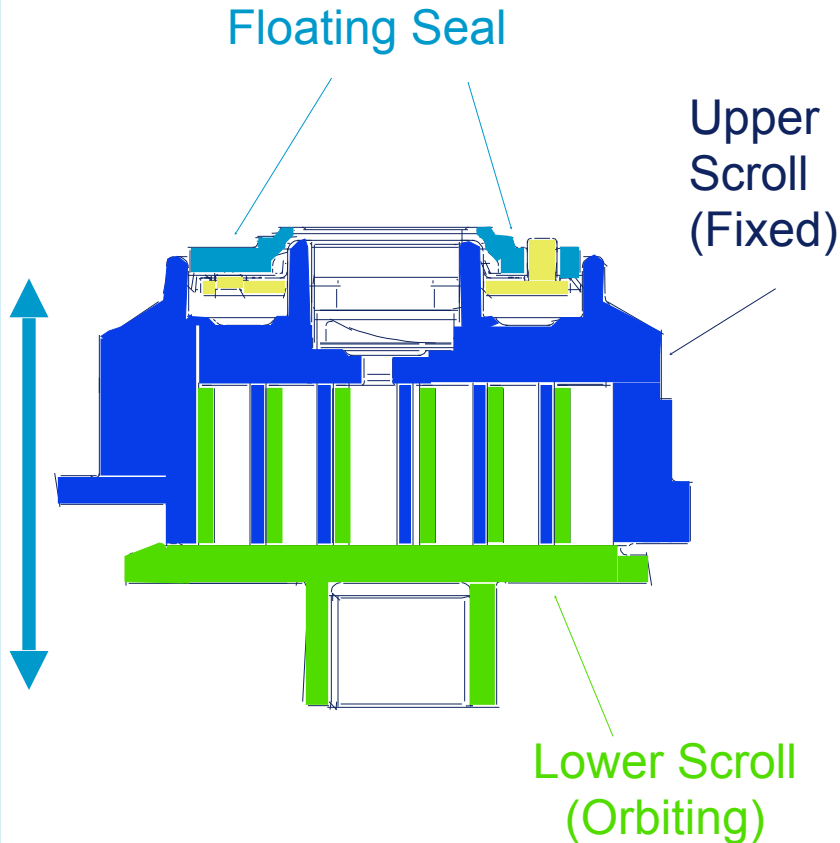

- Maintains constant, even pressure on Scroll tips
- Floating seal is key
- Optimizes tip loading
- Pressure balanced
- Eliminates leakage
- Patented design

Axial Compliance Key To Digital Modulation

Digital Design Comparison

3-7 Ton Digital Design

- Unloads By Venting Top Of Piston To Pull Fixed Scroll Up
- Used On Current 4-6HP Design Over Last 3 Years

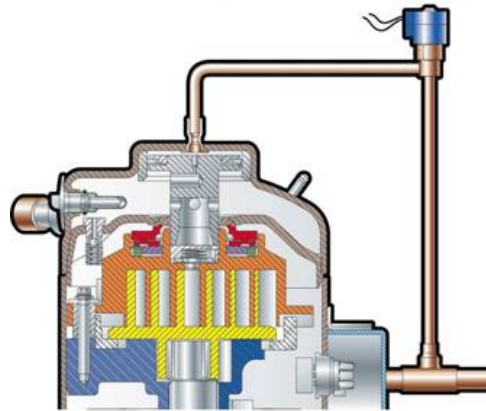

Piston Modulation

8-15 Ton Digital Design

- Unloads By Venting Intermediate Cavity Allowing Fixed Scroll To Move Up
- Tubing Routes Gas From Intermediate Cavity To Manifold In Shell
- External Cartridge Valve Controls Gas Flow
- Able To Handle Higher Pressures

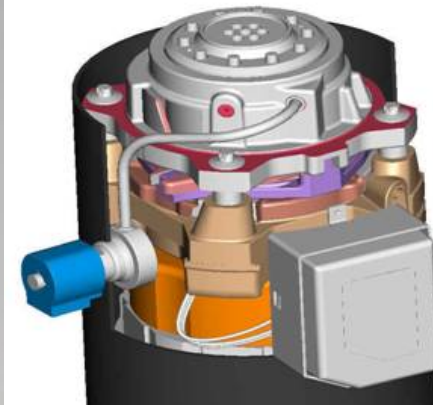

Intermediate Cavity Modulation

Digital Scroll Compressor

Thermistor For High Temperature Cut Out

Discharge Connection

Digital Valve

Suction Connection

Pictorial Only

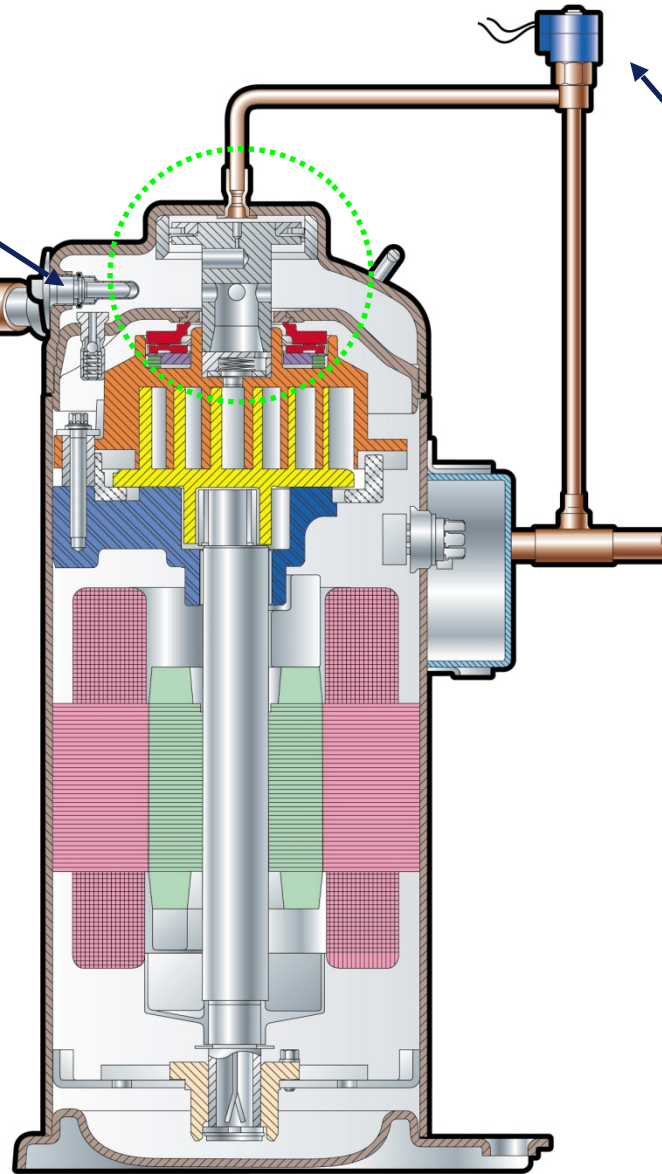

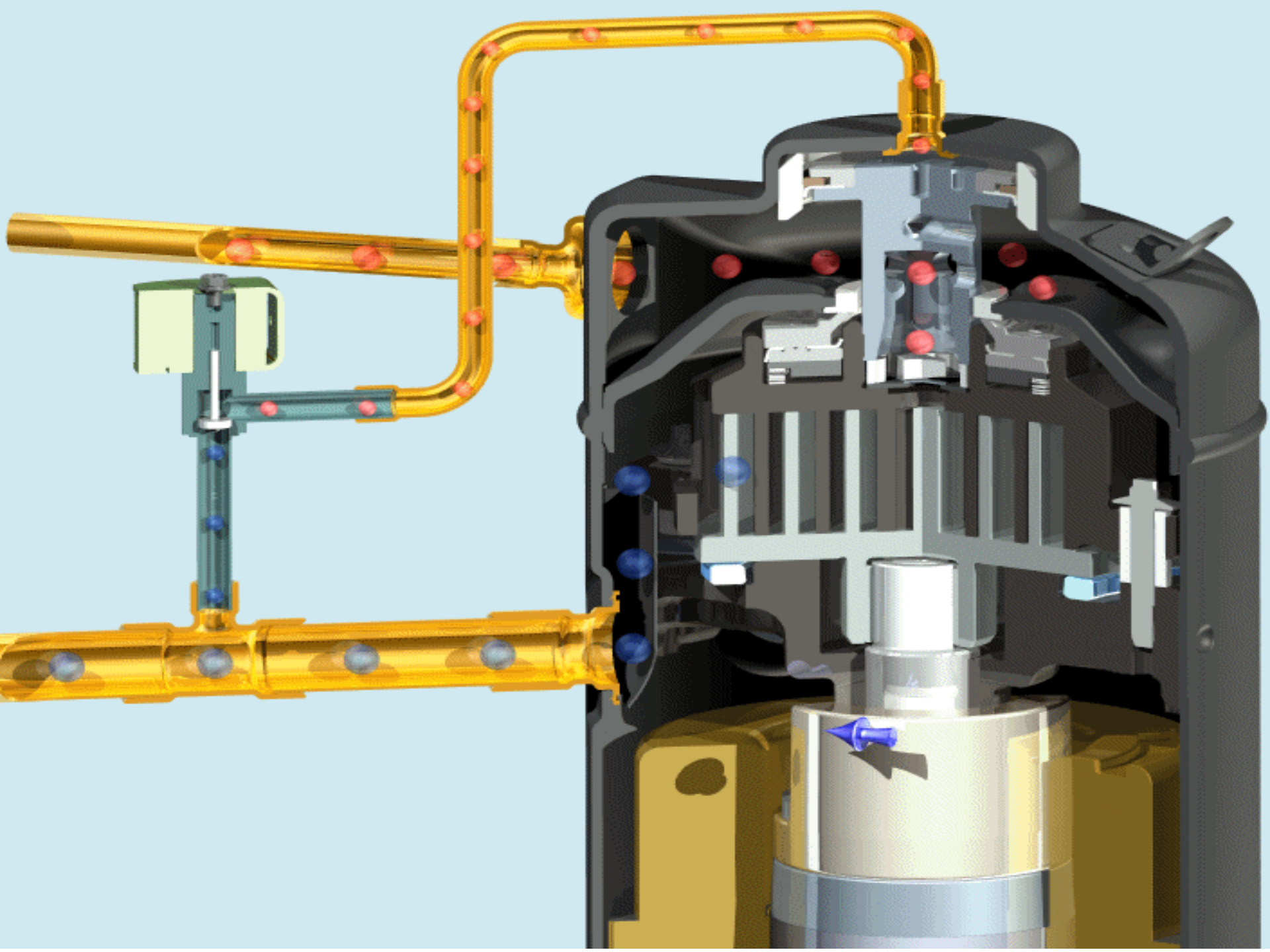

8-17 HP Digital Scroll

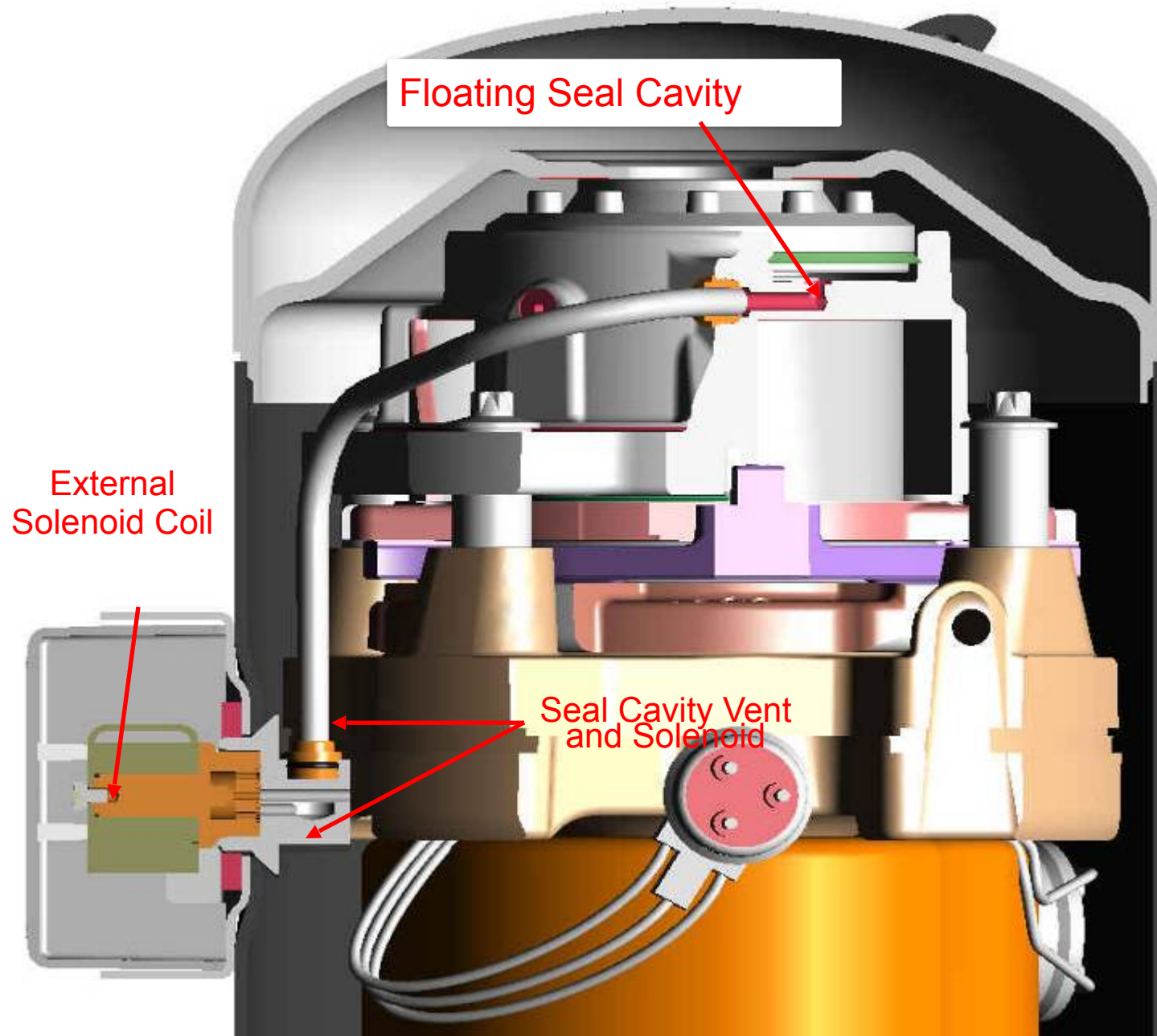

Digital Scroll Modulation – How It Works

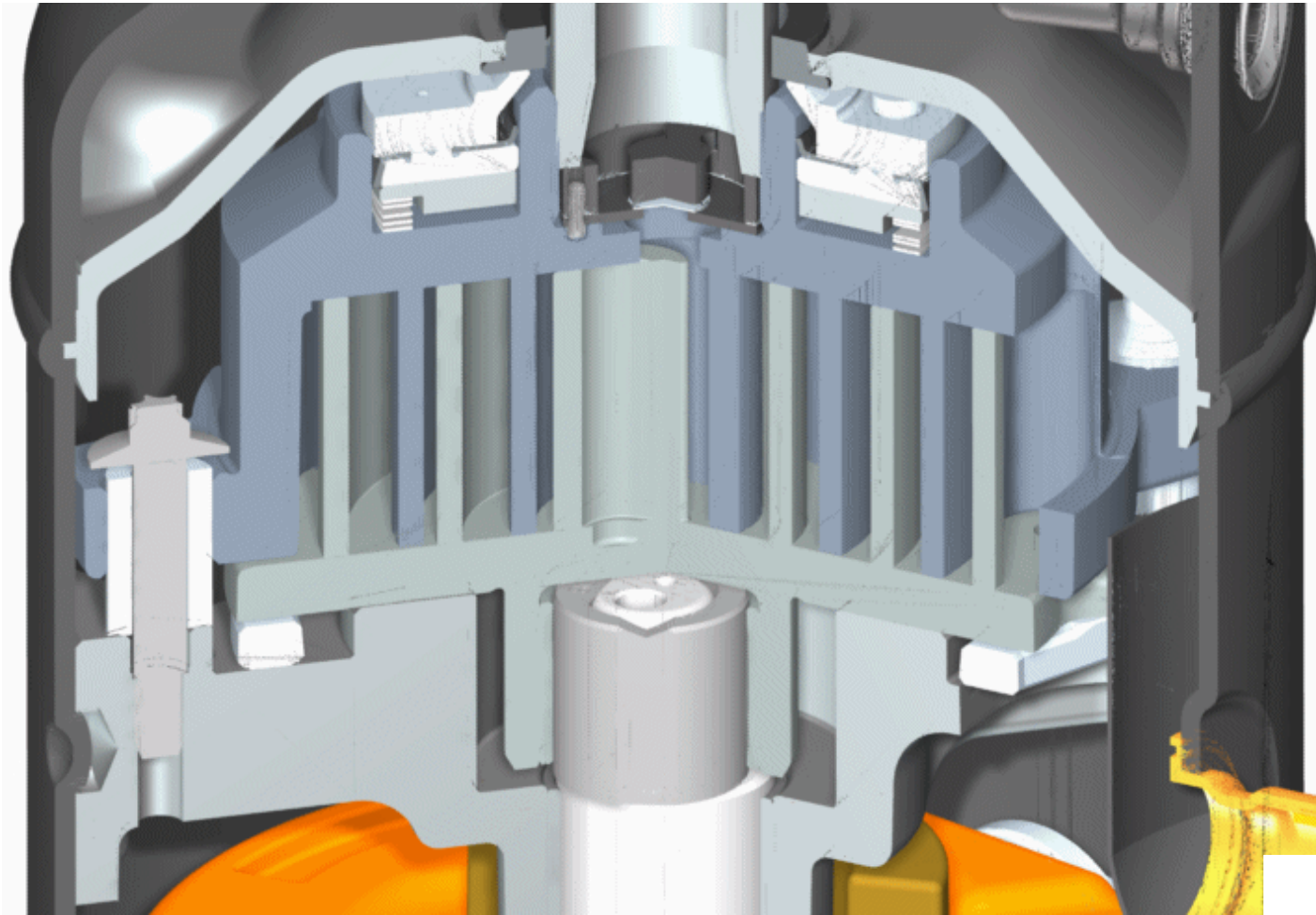

How A Digital Scroll Works



Digital Modulation Mechanism

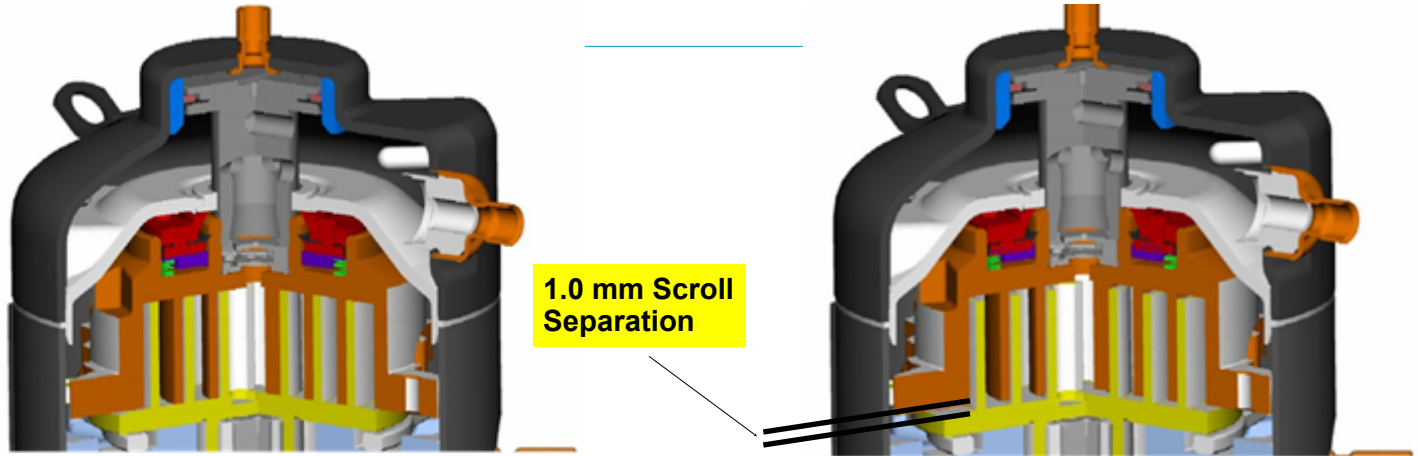

Loaded (1)
Full Capacity

Unloaded (0)
Zero Capacity

20% Output

50% Output

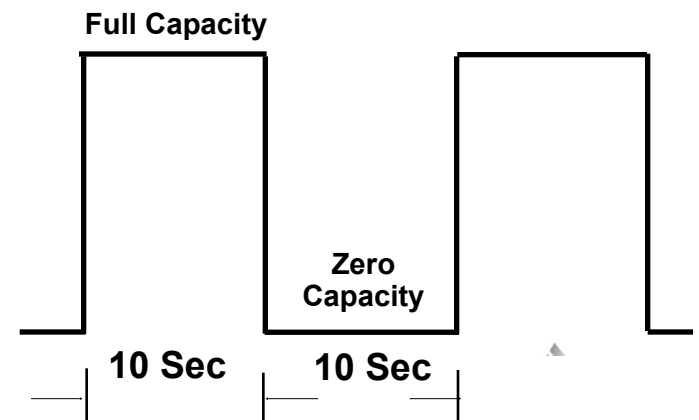
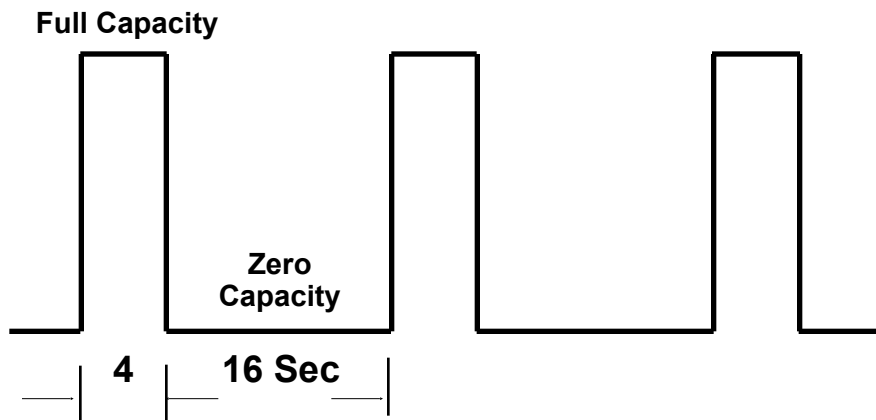

Refrigeration Digital Scroll

Capacity Range (4 Compressor System)

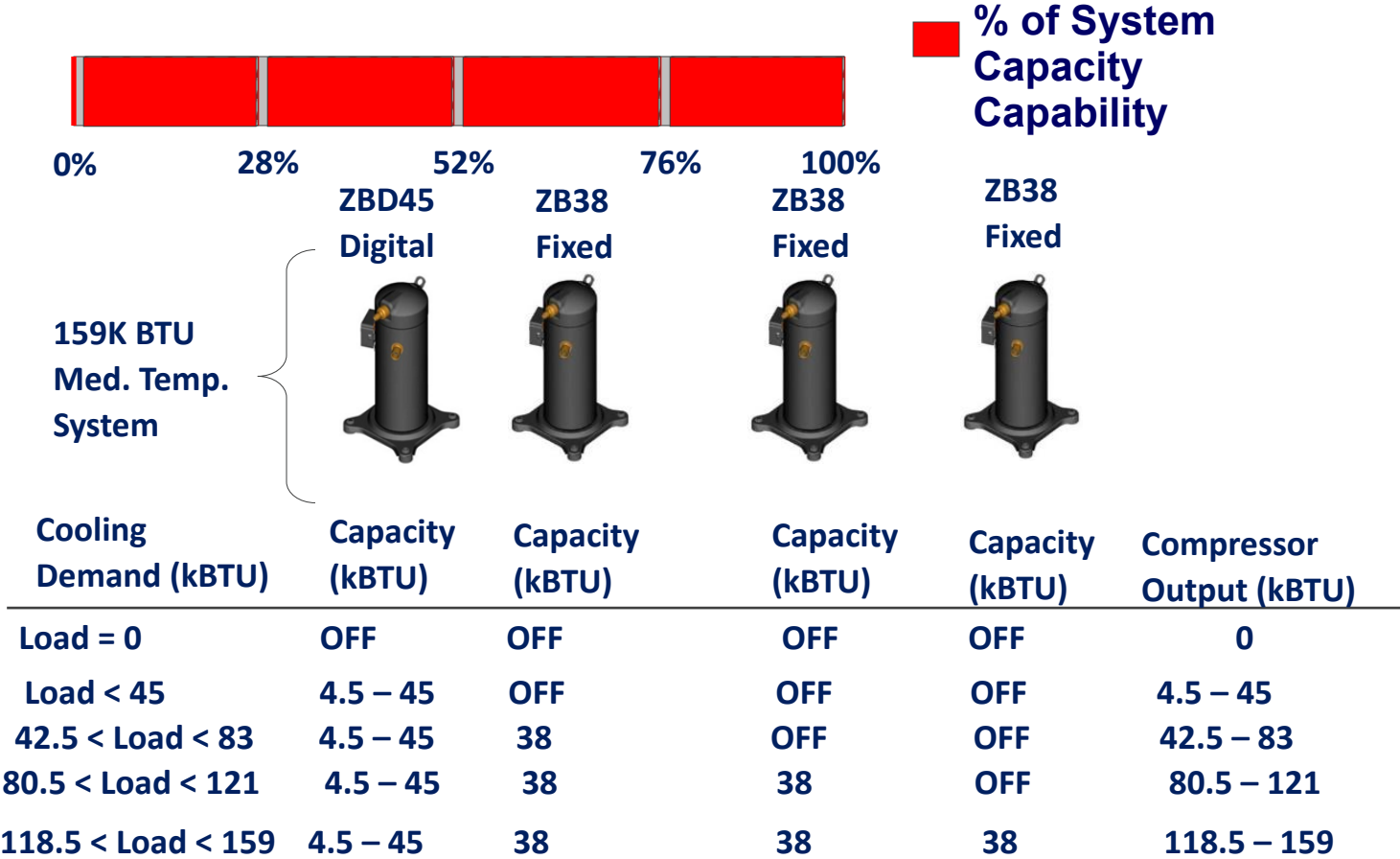

Discus Digital

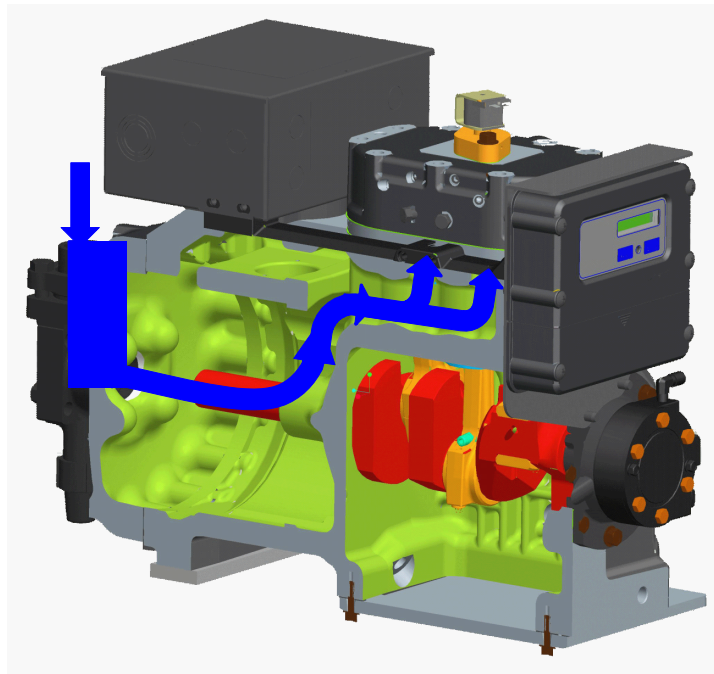

Discus Digital™



Discus Digital Design Comparison

3D Models 10 to 100 %
Capacity Modulation



4D Models 50 to 100 %
Capacity Modulation

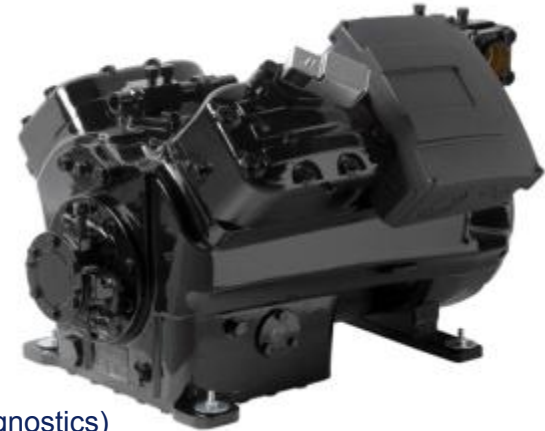

6D Models 33 to 100 %
Capacity Modulation
(Currently Only Available With CoreSense Diagnostics)



Discus Digital Refrigerant Gas Flow

Loaded- De-energized

1. Enters Compressor
2. Passes Through Body
3. Into Valve Plate
4. Compressed by Pistons
5. Exits Compressor

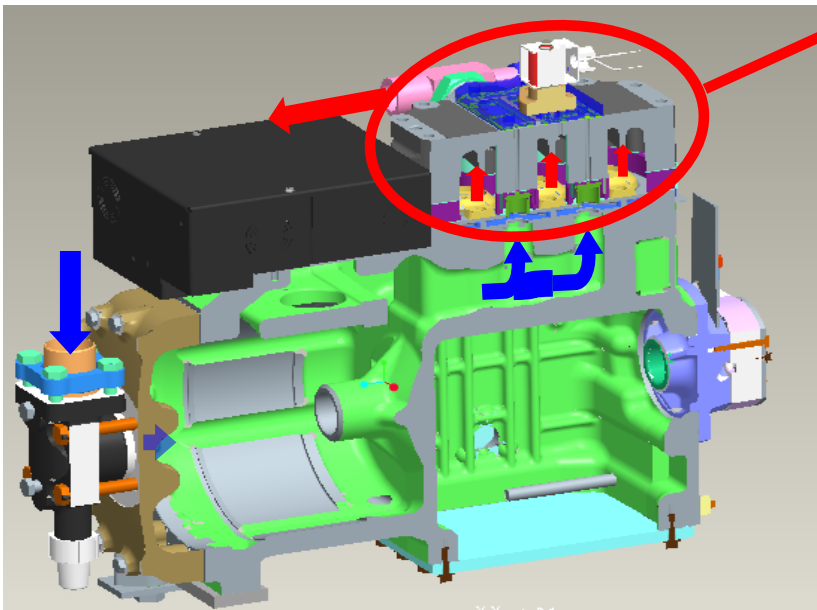

Valve assembly routes **suction** gas above unloader pistons

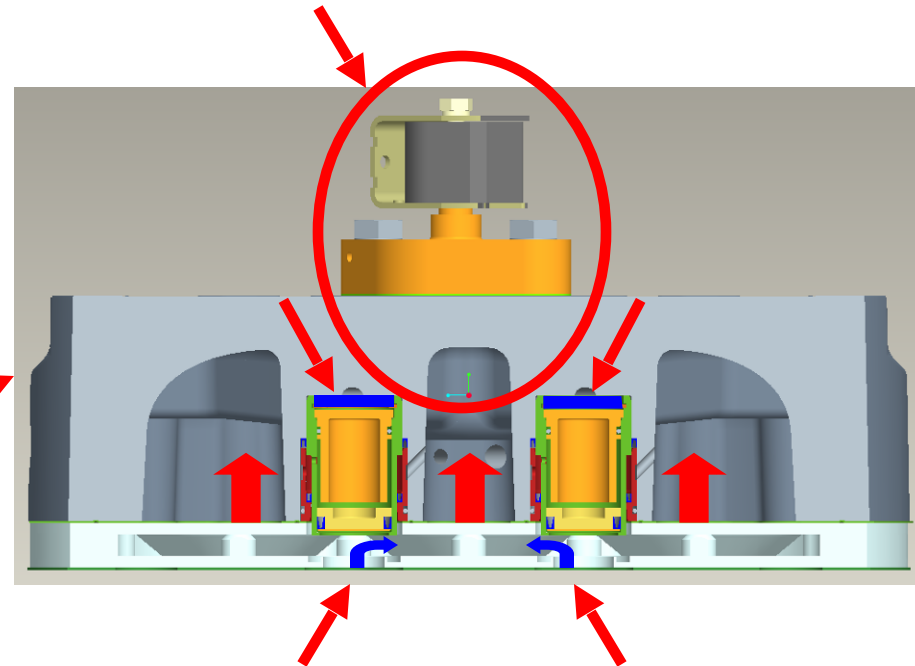

Unloader pistons **allow** suction gas flow into valve plate

Discus Digital Refrigerant Gas Flow

Unloaded- Energized

1. Enters Compressor
2. Passes Through Body
3. 4 Unloader Pistons Block Gas Before Entering Valve Plate

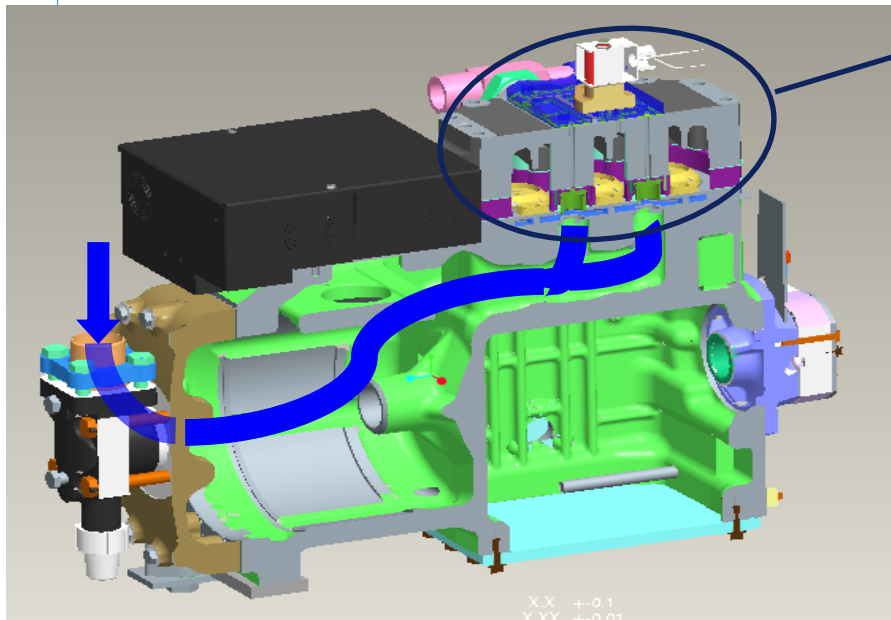

Valve assembly routes **discharge** gas above unloader pistons

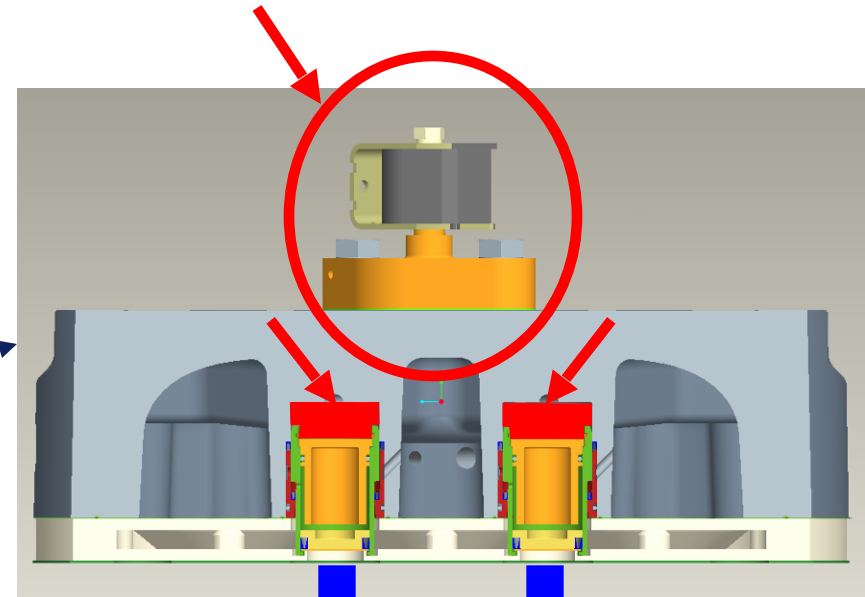

Unloader pistons **block** suction gas flow into valve plate

DISCUS Digital™ Vs Blocked Suction



Controller Decides 50%
or 100% Capacity
100%: Both banks loaded
50%: Energize Unloader

50%

1 Bank Unloaded/1 Bank Loaded

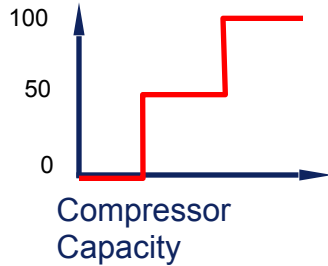

Controller Decides
10-100%
Capacity

Here is How to Deliver
20% Capacity Desired by
System

20%



IDCM

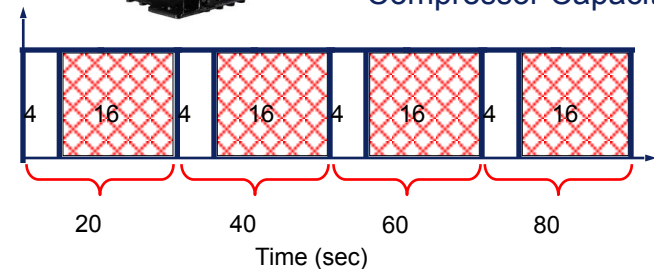
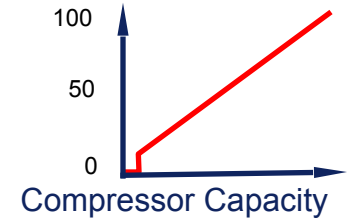
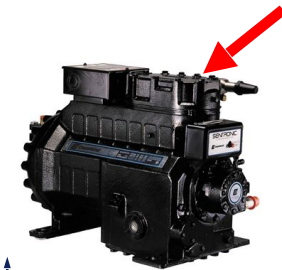

20% Capacity

Blocked Suction unloader
cycles limited to 10
cycles per hour

Discus Digital uses single &
multiple bank with variable
capacity unloading

Discus Digital™ Benefits

- **Precise Control Of Suction Pressure And Temperature**
 - Longer Shelf Life & Less Food Shrink Because Of Minimal Food Temperature Fluctuations
 - More Consistent TXV Operation
- **Reduced Cycling Of Compressors**
 - Extends Contactor Life
 - Extends Compressor Life
- **Reduced Defrost Cycle Time**
 - Tighter Temperature Control Minimizes Formation Of Frost On Evaporator
- **System Efficiency Improvement**
 - Eliminates Over/Under Shooting Of Suction Pressure Set Point
 - Allows Increasing Suction Pressure Set Point
 - Reduces Inrush Current / Power Usage
- **Paradigm Shift In Parallel System Design**
 - No Need For Uneven Paralleling For Compressor Staging
 - Using Common Compressor Selections Simplifies Replacement Needs

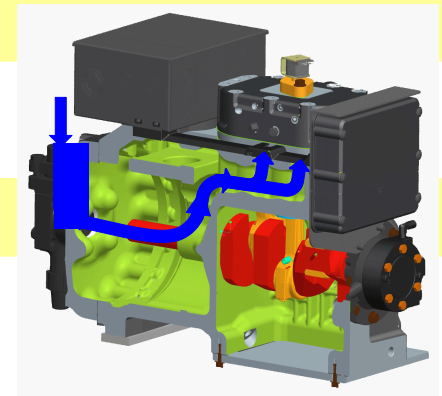

Digital Upgraded Supermarket Application Example

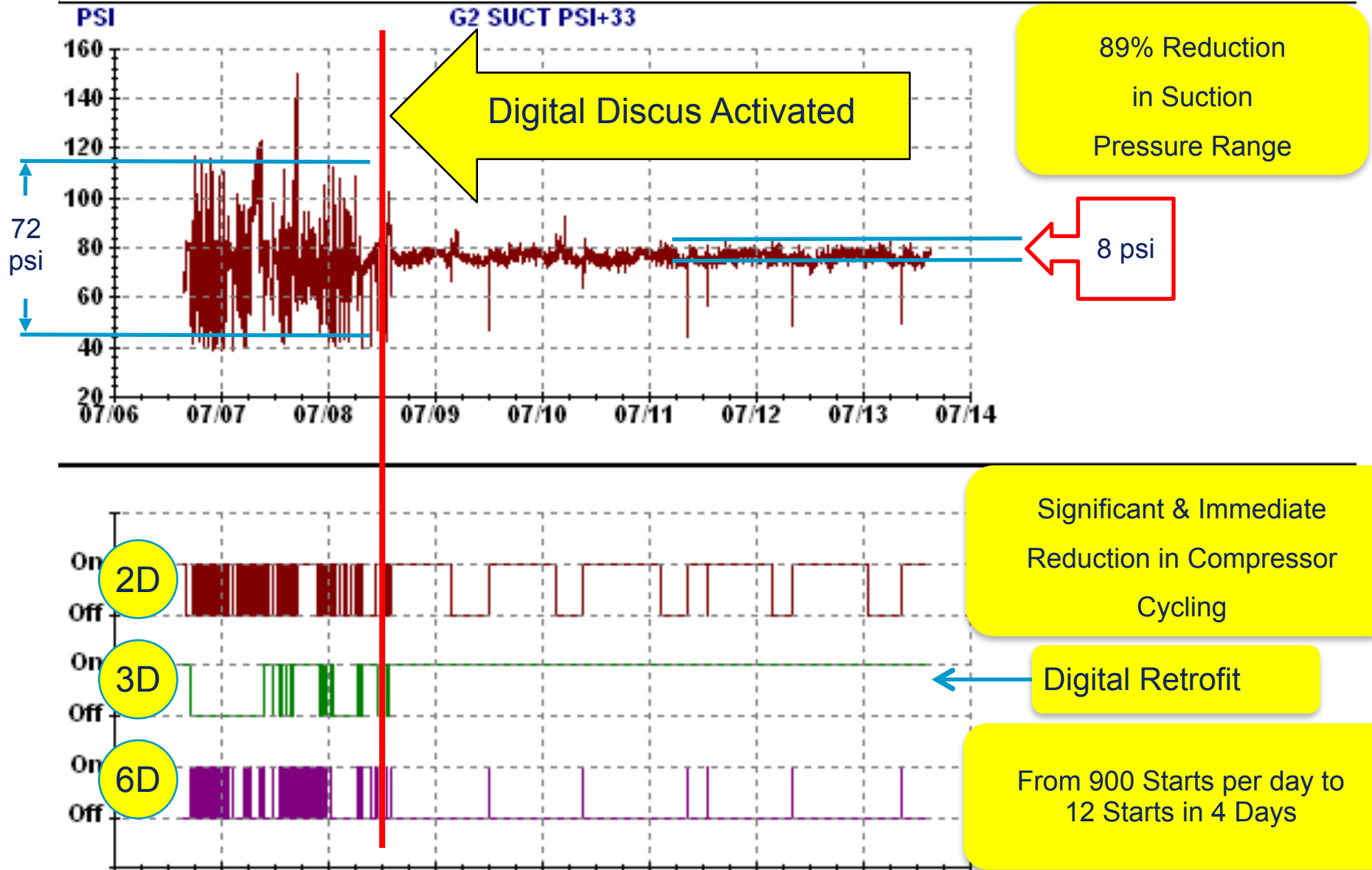

Discus Digital vs Moduload

Digital

- Variable Capacity
- Blocked Suction

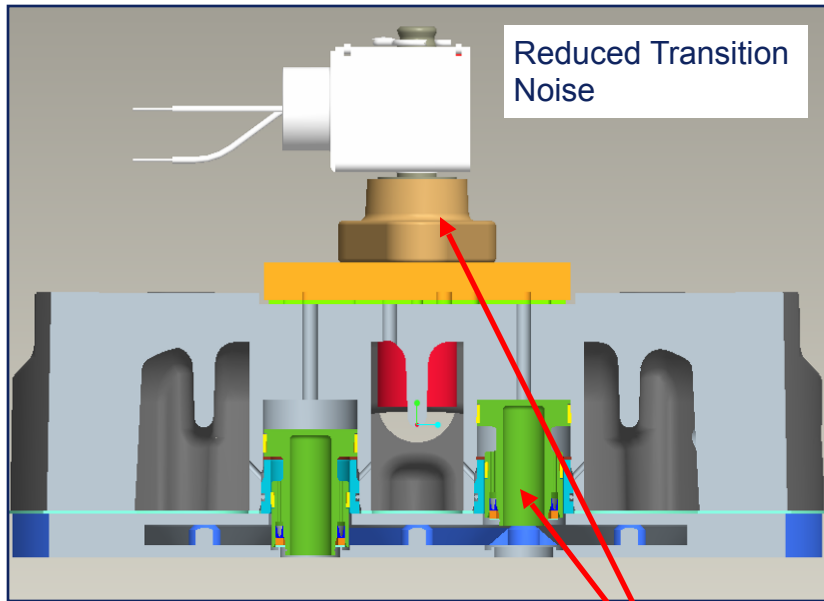

40 Million Cycle Solenoid and Pistons

Pistons Down – Gas Flow Blocked
Pistons Up – Unrestricted Gas Flow

Moduload

- Fixed Capacity Reduction
- Increased Clearance Volume

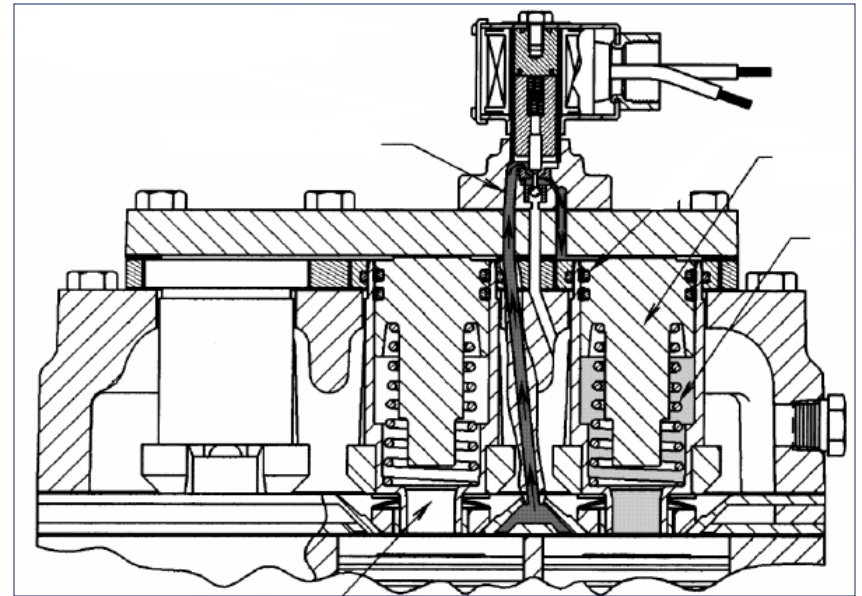

Pistons Down – High Volumetric Efficiency
Pistons Up – Reduced Volumetric Efficiency;
Reduced Capacity

Integration Center MT Rack

Suction Pressure

CONVENTIONAL UNLOADING

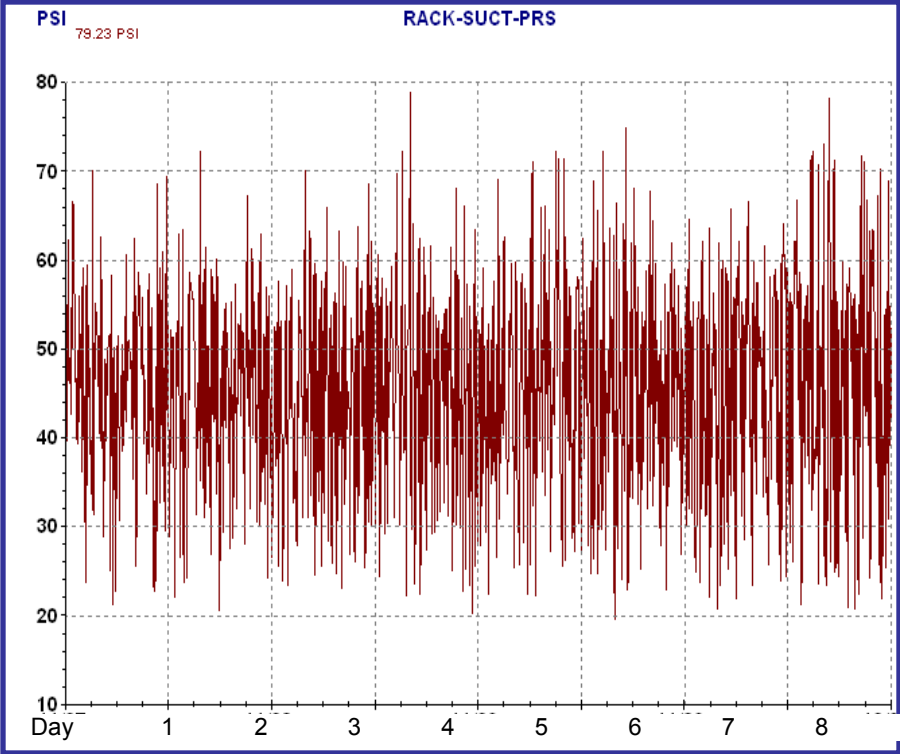

DISCUS DIGITAL

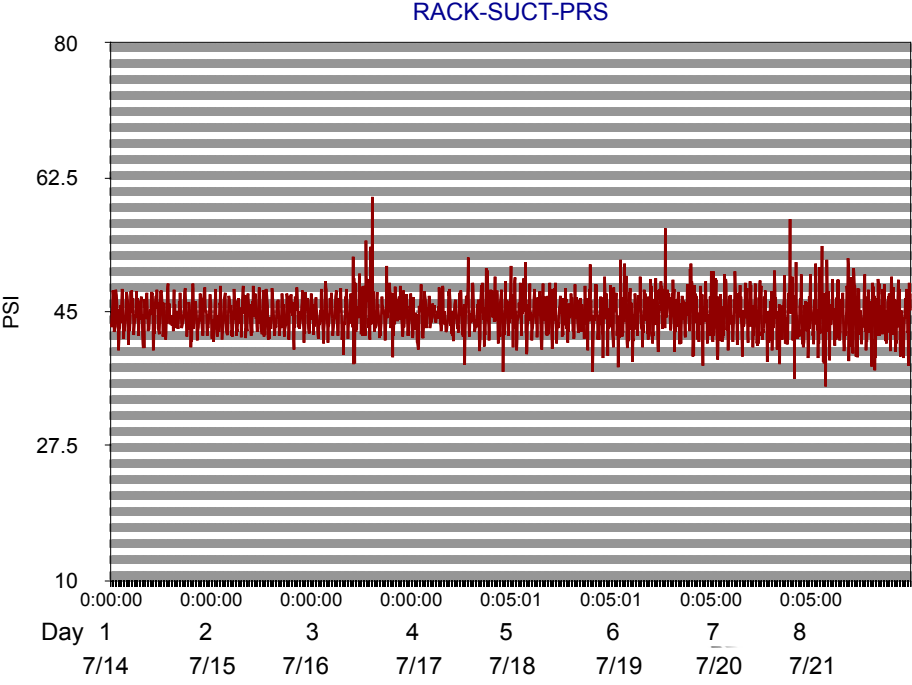

Supporting Literature

- **2009ECT-62**



- **2009ECT-48**

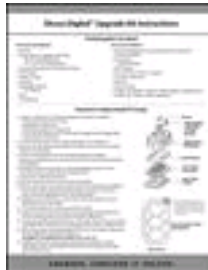

- **AE-1328**



- **AE-1355**



- **AE-1373**



Digital Controller's

Digital Controller Options

Refrigeration/A.C.



- Digital Compressor Controller (IDCM)
 - *Interface Between Digital Compressor And The System Controller.*
 - *Comfort Cooling, Light Commercial A/C Forced Air Systems, Process Applications, Chillers, Rack Refrigeration.*
 - *Scroll And Discus Compatible*



- EC3-D72 Synchronization Controller
 - *Automatic synchronization between EEV and Digital Compressor.*
 - *Requires Master Controller*
 - *Used for air conditioning, refrigeration and industrial applications.*
 - *Single Evaporator Only*
 - *Scroll and Discus*



- XC643 Stand Alone Digital Controller
 - *Standalone Controller*
 - *Single or Multiple Evaporators*
 - *Process Applications, Chillers, Rack Refrigeration and A/C Forced Air Systems.*
 - *Scroll And Discus Compatible*

A.C.



- KMC Stand Alone Digital Controller
 - *Standalone Controller*
 - *Single Evaporator Only*
 - *Comfort Cooling, Light Commercial A/C Forced Air Systems.*
 - *Scroll Only*
 -

Digital Compressor Controller - Overview

- Simple Interface Between Digital Compressor And System Controller
- Provides Control, Protection And Diagnostics
 - Detects 9 Fault Codes
 - 3 Levels Of Protection (Reduced Capacity, Trip, Lockout)
- Same Controller Works On Any Digital Scroll Compressor

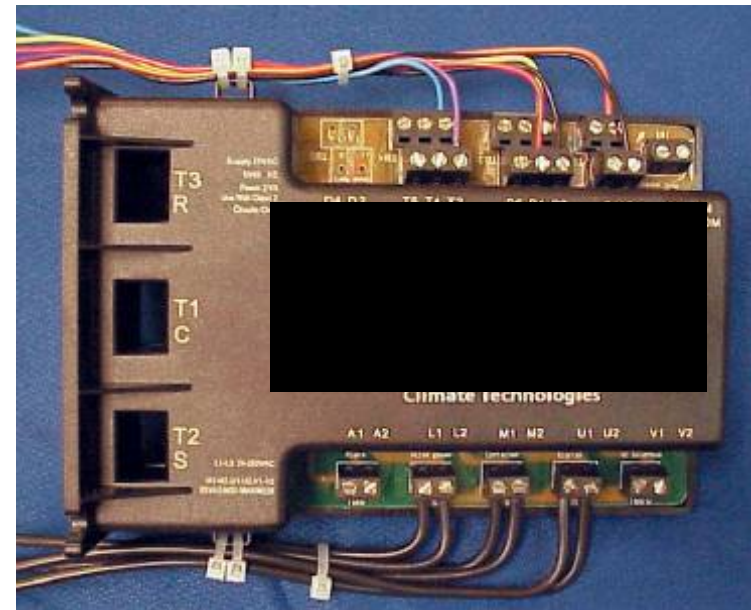

Discus Digital™ Product Overview

- Digital Capacity Modulation Concept Applied To Discus Compressors
- Compressor loading is accomplished by controlling the flow of suction gas entering the cylinders
- Continuous Modulation 100% to 10%
 - 3D, 4D, & 6D Compressors

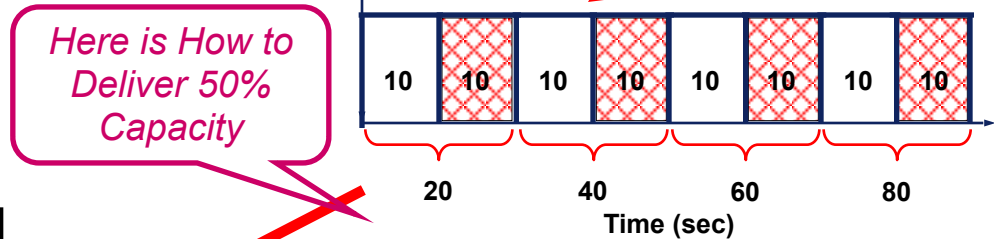
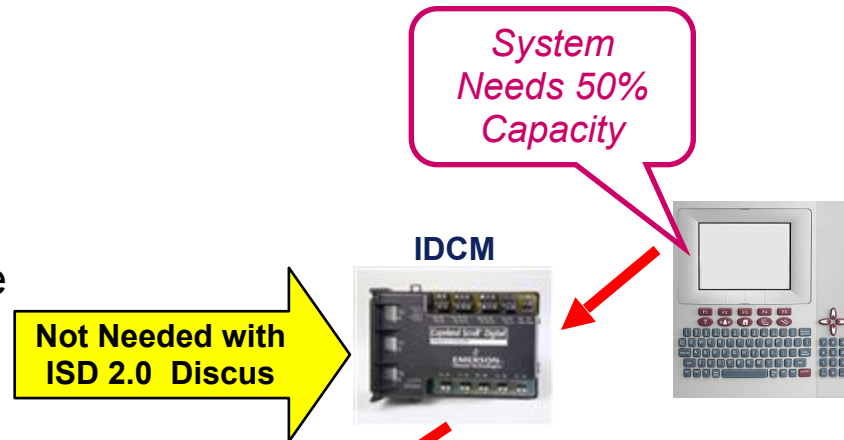

Tightens Temperature Control

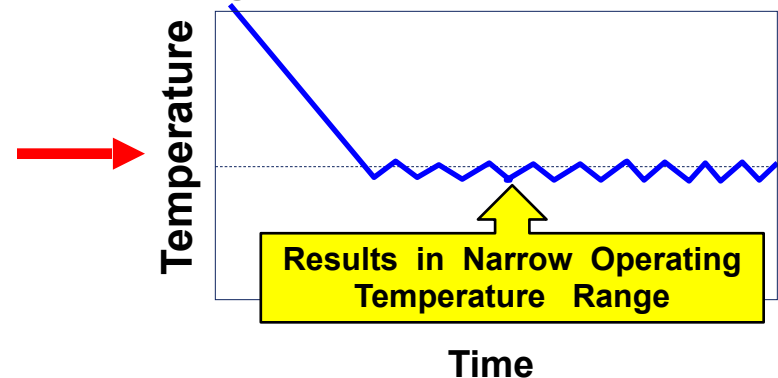

Digital Capable Einstein Controller: V2.3

Important! Select DS For Digital Scroll



E2 Enhanced Suction Status Screen

02-15-06 RX-ABO Unit 1 DRT: 68 19:37:25
ENR SUC STATUS NAMES FULL

Enhanced Section Group Name: Suct: 21.9 [22.0]
EN SUCTION Dsch: 179.0

Stages	Cap	State	Cycles	Status
R1 : DS	6.0	ON	9	Ready
R2 : Comp	3.0	..	17	Ready

Control Status: Observing

Condenser CONDENSER

Variable Capacity: 89.9 %

General Information
Sat Suc Temp: -12.5
Suction Temp: 30.1
Rack Fail : OK
Capacity : 5.4
Capacity % : 59.9

Press enter for a list of actions:

F1: SUCTION F2: CONDENSER F3: CIRCUITS F4: SENSORS F5: SETUP

The screenshot shows a digital display with various status fields. Red circles and arrows highlight specific features: 'DS' in the Stages table, 'Ready' in the Status column, 'Observing' in the Control Status field, and '89.9 %' in the Variable Capacity field.

Integrated Digital Scroll

New Compressor Status Field

New Control Status Field (shows which mode algorithm is in)

Digital Compressor %

EC3-D72 Synchronization Controller

- **Recommend Applications**
 - *Compatible With Digital Scroll and Discus Compressors.*
 - *Process Air Dryers, Chillers, Refrigeration Racks, Walk-in Coolers and Freezers.*
- **Advantages**
 - *Automatic synchronization between EXV and Digital Compressor*
 - *Precise Temperature and Humidity Control.*
 - *Pump Down Feature*
 - *Freeze Protection*
 - *Single Or Dual Compressor Applications Digital & Fixed Compressor.*
 - *TCP/IP Web Browser Configuration*



Valve/Controller for Digital Applications EC3-D72

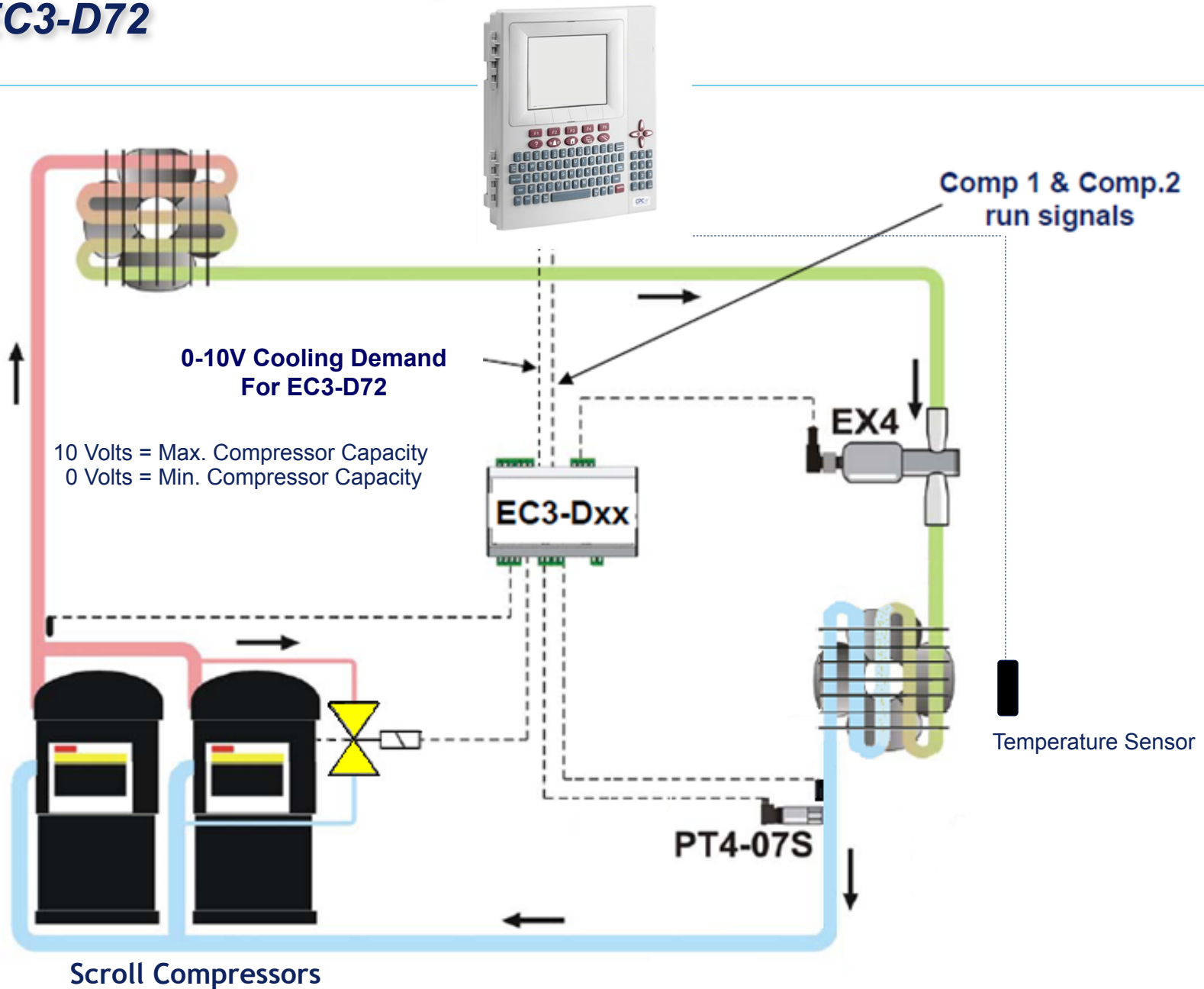

EC3-D72

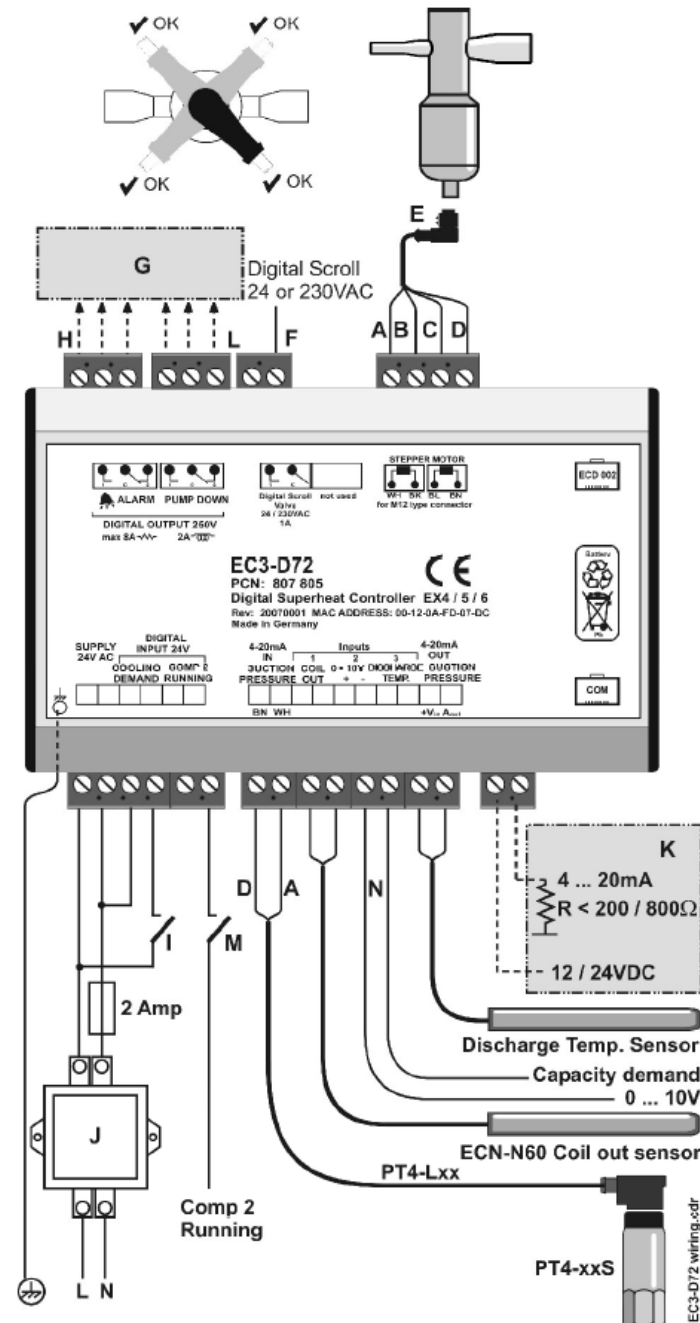

Optional: ECD-002

Default Monitoring Page

EC3 D72 (Rev. 134) (Application 41:15) Web Configuration and Monitoring - Microsoft Internet Explorer

Address: <http://192.168.001.101/>

Navigation buttons: Monitor, Alarms, Service, I/O Configuration, Superheat Configuration, Compressor Configuration, Pressure Configuration, Display Configuration, TCP/IP Configuration

Monitor

Input status	Output status	Alarm
Cooling demand <input checked="" type="checkbox"/>	Alarm <input type="checkbox"/>	<input type="checkbox"/>
Second compressor <input type="checkbox"/>	Compressor <input checked="" type="checkbox"/>	<input type="checkbox"/>

Compressor controller	Superheat controller
Discharge temperature: <input type="text" value="78.94"/> °F	Evaporating pressure: <input type="text" value="49.73"/> psig
Capacity: <input type="text" value="34.65"/> %	Evaporating temperature: <input type="text" value="30.18"/> °F
	Coil Out Temperature: <input type="text" value="55.22"/> °F
	Superheat: <input type="text" value="25.03"/> R
	Superheat Setpoint: <input type="text" value="9.54"/> R
	Valve opening: <input type="text" value="51.21"/> %

Evaporator status
Superheat control
MOP
Pump down
Manual

Done Internet

XC643 Stand Alone Digital Controller Overview

- Recommend Applications
 - *Compatible With Digital Scroll and Discuss Compressors.*
 - *Process Air Dryers, Chillers, Refrigeration Racks, Walk-in Coolers and Freezers.*
- Advantages
 - ***Standalone, No Master Controller Required.***
 - *Controls On Pressure Or Temperature.*
 - *Controls Up To Two Condenser Fans Separately.*
 - *Reads Pressure Or Temperature Inputs.*
 - *Single Or Dual Compressor Applications Digital & Fixed Compressor.*



Stand Alone Digital Controller Features

Set Points

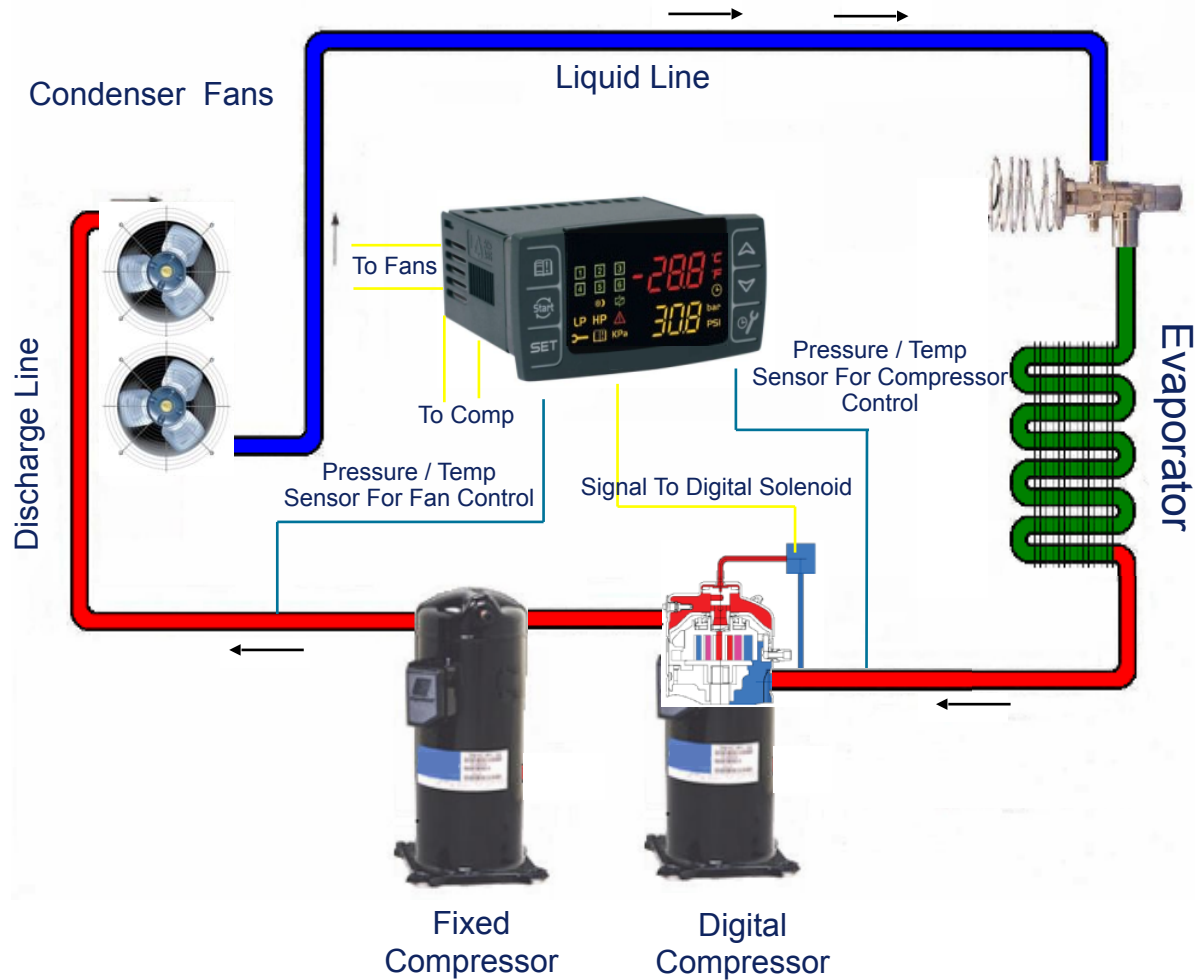

- 1 Control Type Press/Temp
- 2 Compressor Set Point
- 3 Fan Set Point
- 4 Fixed Comp or None
- 5 Fan #1 or None
- 6 Fan #2 or None
- 7 Refrigerant Type
- 8 Fan Control - Y/N
- 9 Temperature Unit °F or °C
- 10 Pressure Unit PSI, Bar or Pa
- 11 Proportional Band For Compressor Control
- 12 Integral Time For Compressor Control
- 13 Time Delay Between Starts of Loads
- 14 Proportional Band For Fan Control

Digital Modulation Over Larger Capacities

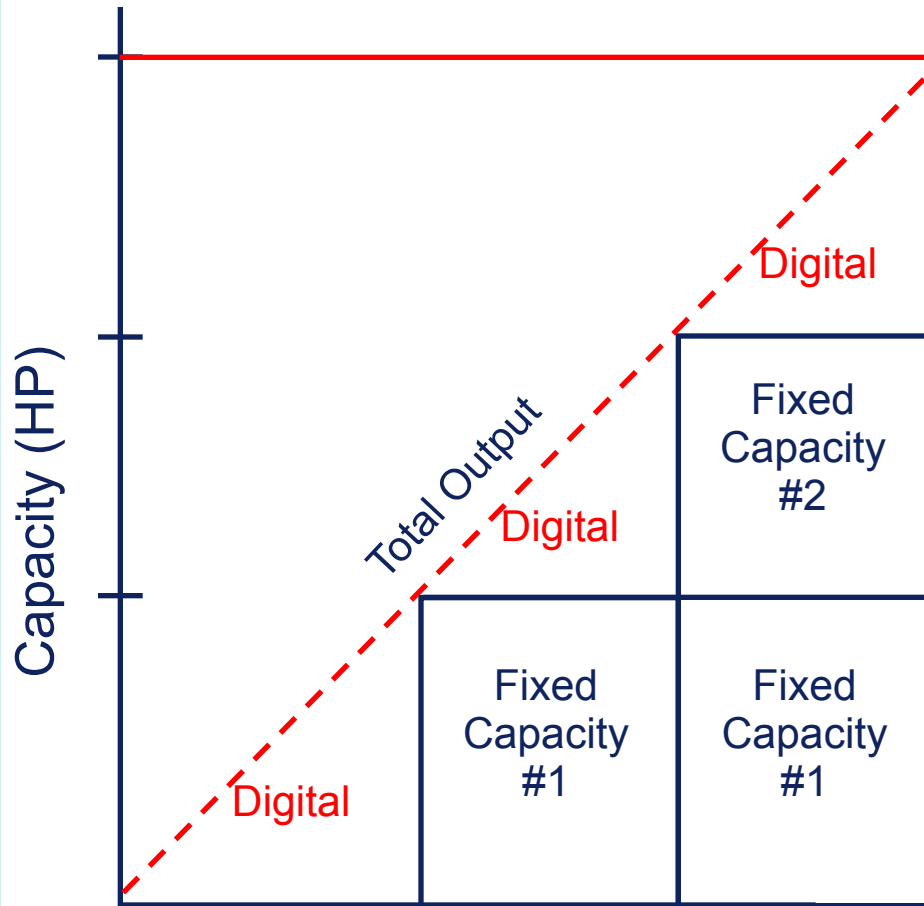

- Digital Can Be Used In Parallel With Fixed Capacity Scrolls To Get Even Wider Range Of Capacities
- Power Savings Still Follow The Same Line
- Leverages The Cost And Capability Of One Digital Over Larger Systems

Retrofit Product Review

Discus Digital Design Comparison

3D Models 10 to 100 %
Capacity Modulation



4D Models 50 to 100 %
Capacity Modulation

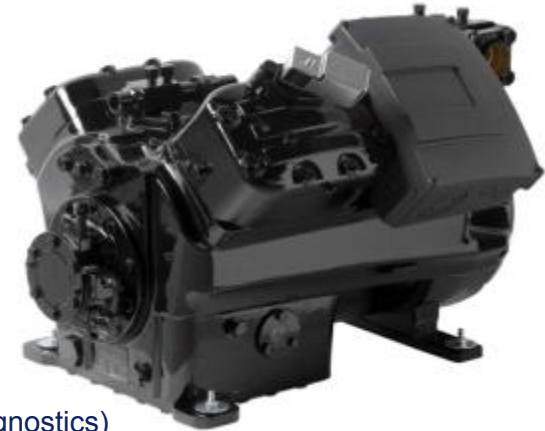

6D Models 33 to 100 %
Capacity Modulation
(Currently Only Available With CoreSense Diagnostics)



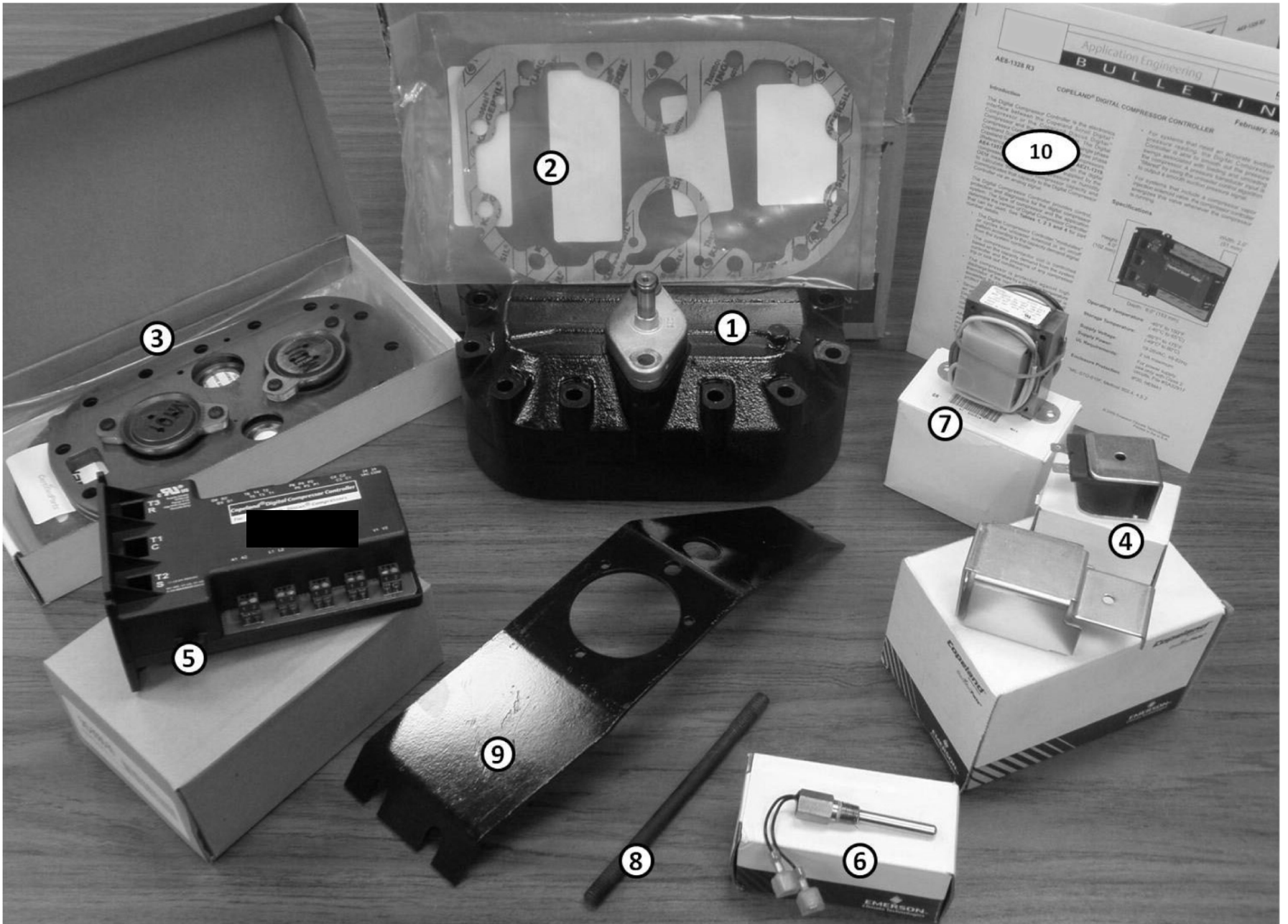

Figure 1 – Items in a Typical Discus Digital Upgrade Kit

Digital Upgrade Kit – Medium Temperature

Standard Discus Compressors (Non Intelligent Store Discus)

<i>Part Number</i>	<i>Description of Items Included</i>
980-3000-00	Head – Service Kit
	Plate – Valve Kit
	High Cycle Solenoid Coil 120v-50/60Hz
	High Cycle Solenoid Coil 220v-50/60Hz
	Bracket – Solenoid
	Fitting – Knockout Plug
	Screw-Hex Head
	Digital Compressor Controller (IDCM Board)
	Sensor – Temperature Probe
	24v Transformer

Digital Upgrade Kit – Low Temperature

Standard Discus Compressors (Non Intelligent Store Discus)

<i>Part Number</i>	<i>Description of Items Included</i>
980-3000-01	<i>Head – Service Kit</i>
	<i>Plate – Valve Kit</i>
	<i>High Cycle Solenoid Coil 120v-50/60Hz</i>
	<i>High Cycle Solenoid Coil 220v-50/60Hz</i>
	<i>Bracket – Solenoid (2)</i>
	<i>Fitting – Knockout Plug</i>
	<i>Screw-Hex Head</i>
	<i>Digital Compressor Controller (IDCM Board)</i>
	<i>Sensor – Temperature Probe</i>
	<i>Bracket – Fan Motor</i>
	<i>24v Transformer</i>
	<i>Resistor (used on DCC with Demand Cooling)</i>

Digital Compressor Controller Mounting

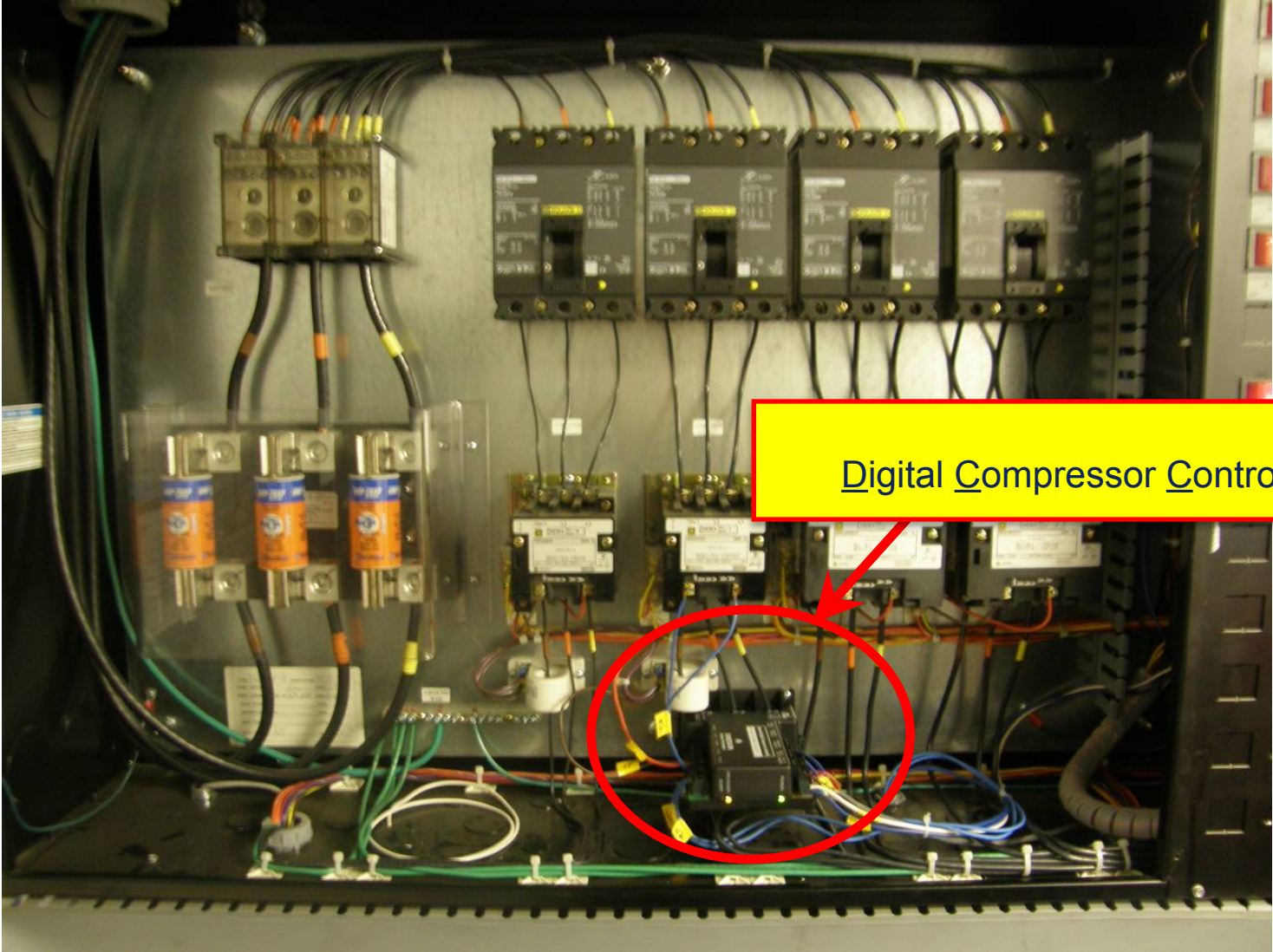

Digital Compressor Controller

Supermarket retrofit 3D





Variable Frequency Drives

Education You Can Build On

Variable Frequency Drives

The advantages of varying compressor speed are:

- The load is more closely matched with minimal variation in evaporating pressure and fluctuations in load temperature are minimized.
- Better system efficiency at part load
- Extended lifetime of equipment due to continuous operation instead of cycling
- Low starting current avoids the need for assisted start devices
- With controlled speed increase from standstill there is less risk of sudden liquid or oil return to the compressor on start up

Variable Frequency Drives

When considering a VFD, the following points should be taken into account:

- Loss of efficiency unless care is taken with system design and control
- Conventional capacity control methods may not be used with a VFD (i.e. blocked suction, or Digital) on the same compressor
- Vibration resonance may occur at certain speeds and these are very difficult to predict.
- Risk of electrical disturbance to control signals due to the high-frequency content of the drive's output waveforms

Variable Frequency Drives

13. Typical VFD Parameter Set Up for Discus and Scroll Refrigeration Compressors

The following is a list of some recommended control parameters for configuring a VFD.

- minimum frequency per **Table 1**
- maximum frequency per **Table 1**
- 3 sec Acceleration ramp to nominal 60 Hz (20 Hz/second) at startup to ensure lubrication
- Motor rated current (A) per compressor data sheet. Typically used for current limit protection.
- Motor Rated Speed: Recommend setting this to synchronous speed to disable slip compensation on drives with this feature. It can be set to nameplate rated speed to enable slip compensation, but the user must verify current increase is not excessive.
- Motor rated voltage per nameplate
- 2 - 3 kHz Switching frequency
- Motor rated frequency per nameplate
- Open loop V/f (V/Hz) control mode
- Impulse voltage (slew rate) of PWM waveform complies with IEC Technical Specification 60034-17 limit of 1.35 kV / microsecond maximum.

Note: In most variable frequency drives, you can also program "skip" frequencies to avoid vibration resonance that may occur at certain speeds.

Model Family	Speed Range	Notes
3D, 4D & 6D	25 – 60 Hz	
Refrigeration Scroll (ZB, ZS, ZF) other than those listed below	45 – 60 Hz	
ZB06KAE ZB07KAE ZB08KAE	50 – 60 Hz	
ZRHV72KJE ZBHV45KJE	Per AE4-1343	
ZCH72C3G ZCH72C4G	35 – 70 Hz	

Table 1- Approved operating range for fixed-capacity Copeland compressors



CO2 Systems

Education You Can Build On

Typical CO₂ Transcritical Booster System

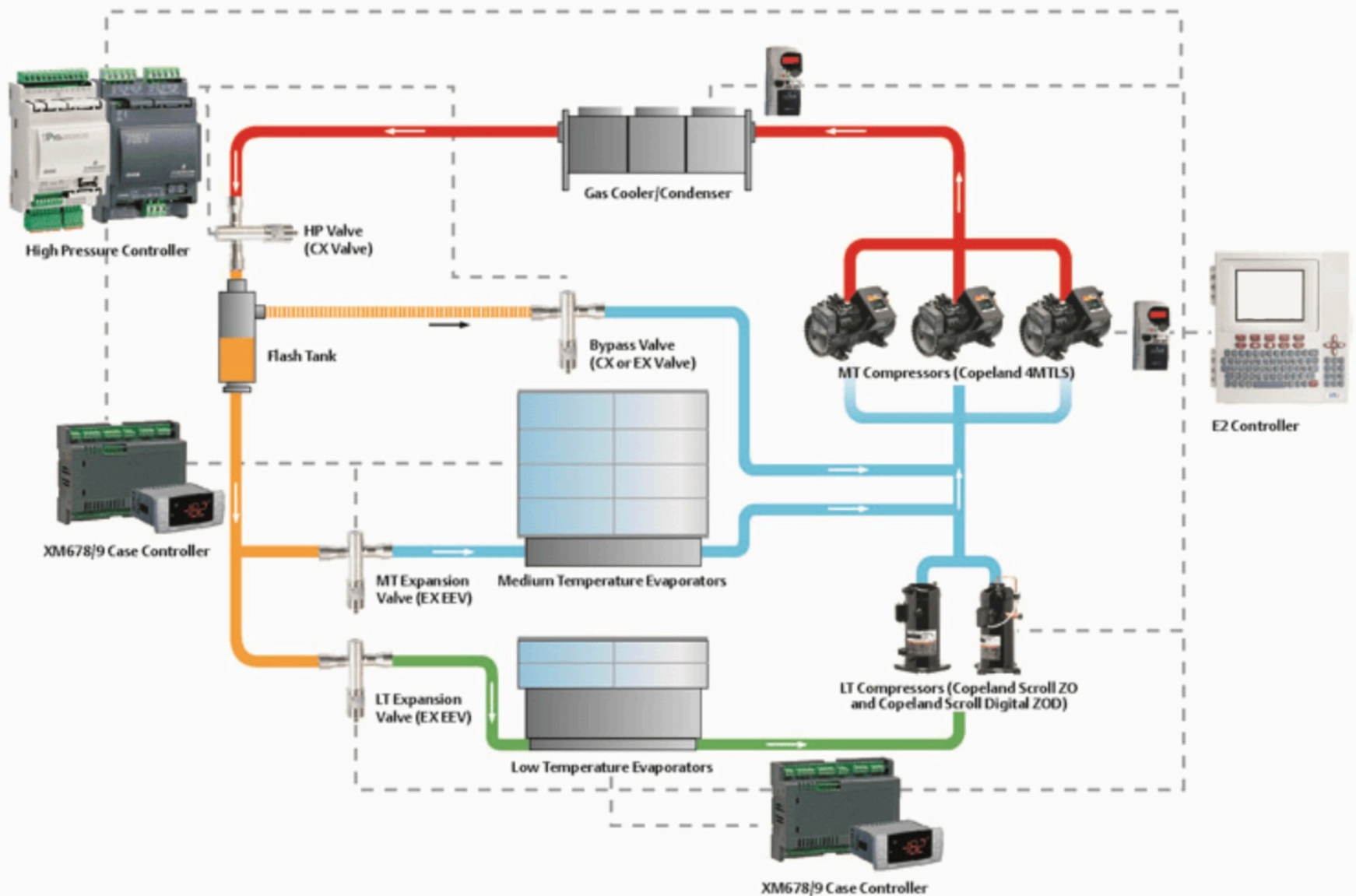

Typical CO₂ Hybrid Cascade System

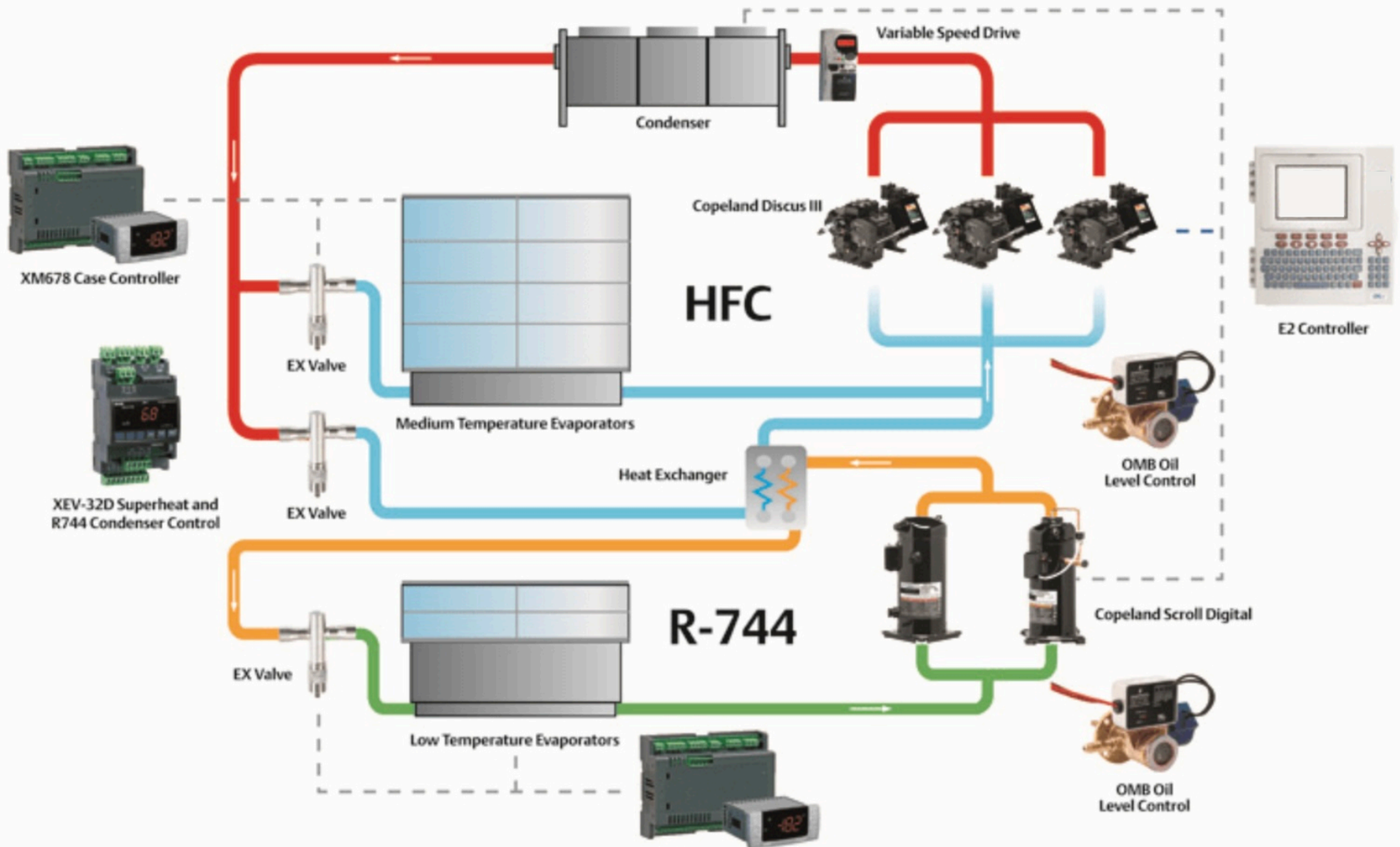

Software/ APP Support

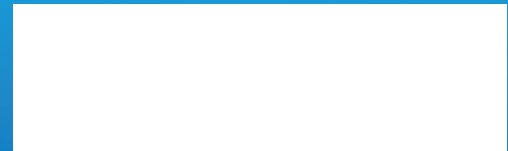



Search



Search



Enter Serial / Part / Model Number

SCAN



Job



Support



Resources



More



Your Recent 10 Searches

ZPT570KCE-TE5



ZPDT36MCE-TE7



998-2669-00



4DR3A300E-FSD



CS12K6E-PFV



6DY3R32ME-FSD



6DW3-3000-FSD



CS24K6E-TF5



CS24K6E-PFV



MTZ022-1



< Back

6DY3R32ME-FSD

- Search >
- Job >
- Support >
- Resources >
- More >

Search Result (22)

Frequency Any ▾ **Refrigerant** Any ▾

Product Type: Semi-Hermetic **Oil:** POE (Polyol Ester Oil)

Application: Air Conditioning	Electrical: 460-3-60	Refrigerant: R-22	>
Application: Air Conditioning	Electrical: 460-3-60	Refrigerant: R-407A	>
Application: Air Conditioning	Electrical: 460-3-60	Refrigerant: R-407A	>
Application: Air Conditioning	Electrical: 460-3-60	Refrigerant: R-407C	>
Application: Air Conditioning	Electrical: 460-3-60	Refrigerant: R-407C	>
Application: Med Temp. Low Cond.	Electrical: 460-3-60	Refrigerant: R-22	>
Application: Med Temp. Low Cond.	Electrical: 460-3-60	Refrigerant: R-22	>
Application: Med Temp. Low Cond.	Electrical: 460-3-60	Refrigerant: R-407A	>
Application: Med Temp. Low Cond.			>



- Back
- Summary >
- Mechanical >
- Electrical >
- Performance >
- Where To Buy >
- Cross Reference >
- Warranty Status >
- Troubleshooting >
- Diagnostics >
- Nomenclature >
- Bill-of-Materials & Ref... >
- Service Parts >
- Accessories >
- Wiring Diagram >
- Publications and Bulle... >

6DY3R32ME-FSD



Summary

Status: Service Replacement

Capacity (Btu/hr):	340,000
Application:	Air Conditioning
Refrigerant:	R-407C
Product Type:	Semi-Hermetic
Oil:	POE (Polyol Ester Oil)
Service Oil Type:	POE (Polyol Ester Oil)
Voltage:	460
Phase:	3
Frequency (Hz):	60





Application Engineering Bulletins



 Keywords

 Sections

 Refrigerants / Oils

 History

Close

Search Bulletins

VFD



AE21-1369 - Use of Variable Frequency Drives (VFDs) With Copeland Scroll™ and Copeland Discus™ Fixed Capacity Compressors in Refrigeration Applications

AE4-1388 - 20 to 40 Ton ZP*KC and ZR*KC Copeland Scroll™ Air Conditioning Compressors

Copeland™ Variable Speed Reciprocating Compressor Drives for A*V* Compressor Family



"VFD"



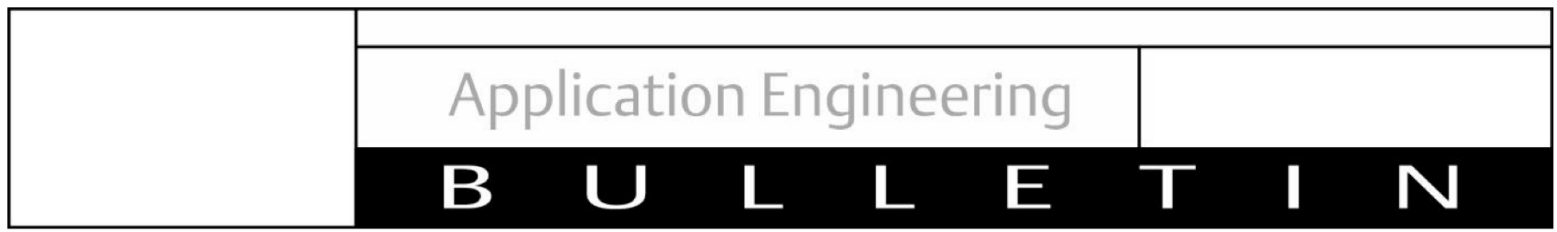

AE21-1369 R5

August 2021

Use of Variable Frequency Drives (VFDs) With Copeland Scroll™ and Copeland Discus™ Fixed Capacity Compressors in Refrigeration Applications

TABLE OF CONTENTS

Safety 2
Safety Instructions..... 2
Safety Icon Explanation 2
Instructions Pertaining to Risk of Electrical Shock, Fire, or Injury to Persons..... 3
Safety Statements..... 3
1. Introduction 4
2. Operation of a Variable Frequency Drive..... 4
3. Evaluation and Important Considerations 4
4. Limits of Use With Copeland Fixed-Capacity Compressors..... 5
5. Approved Voltage/Frequency Ranges With Standard Motors 5
6. Minimum Speed..... 5
7. Effect of the VFD on Performance and Power Input 5
8. Control of VFD Frequency..... 5
9. Start Contactor Positioning..... 5
10. Starting and Ramp Up 6
11. Electrical Shielding and Voltage Rise..... 6
12. Vibration 6
13. Typical VFD Parameter Set Up for Discus and Scroll Refrigeration Compressors 7
General Guidelines and More Information 7

TABLE OF FIGURES

Figure 1 - Voltage-Frequency Relationship 8
Figure 2 - Utility vs VFD Voltage Waveform 8



Product Selection Software



Product Selection Software is an integrated PC based software tool that allows users to select and generate compressor performance. Additionally, system designers can simulate a refrigeration rack of up to 10 compressors, perform seasonal analysis and determine its annual operating cost. Users can generate non-standard conditions compressor performance, download rating coefficients, view reference drawings, wiring diagrams, bill-of-materials and perform simplified system analysis. Other supporting functions available in the tool are:

- View / search Application Engineering Bulletins
- Thermodynamic & Transport properties of refrigerants
- English and Metric engineering units
- English and Spanish capability
- Generate refrigeration loads of walk-in coolers and freezers
- Capability to perform AEER Analysis using user selected compressors

System Requirements

A Pentium® 4, 500 MHz Processor, 1 GB RAM (1.5 GB RAM Recommended), 600 MB Free Hard Disk Space, Windows® XP or Vista or Windows 7 or Windows 10 Operating System (32 bit or 64 bit), Microsoft Internet Explorer® Version 6.0 or Higher, Adobe Reader Version 8.0 or Higher (Included in Installation) and 1024x768 Minimum System Resolution.

[INSTALL NOW ↗](#)

[CONTACT SUPPORT ↗](#)

Inputs

Evaporator Temperature (°F):

Condensing Temperature (°F):

Return Gas Temperature (°F): 

Evaporator Superheat (°F):

Compressor Superheat (°F):

Total Subcooling (F):

Results

Compressor Capacity (Btu/hr): 

Net Refrigeration Effect (Btu/hr):

Power (W):

Compressor EER (Btu/Wh):

Evaporator EER (Btu/Wh):

Refrigerant Flow Rate (lb/hr):

Current (Amps):

Isentropic Efficiency (%):

Liquid Temp. (°F):

Discharge Temp. (°F):

Cond. Heat Rejection (Btu/hr):

Subcooling Heat Rejection (Btu/hr):

Report

Reset

Calculate

Reports

[Performance: Full Matrix](#)

[Operating Envelope](#)

[Reference Drawing](#)

[Wiring Diagram](#)

[System Report](#)

[Summary](#)

[Estimate Electrical Current](#)

[Condenser Heat Rejection](#)

[Mechanical Room Ventilation Air](#)

[Export Compressor Coefficients](#)

Notes: Net Refrigeration Capacity is the amount of useful cooling delivered to refrigerated space. Discharge Temperature Estimation Accuracy ± 10 °F.

Main Menu

Product Information

Compressors

Default

Temper

Inputs

Evaporator T

Condensing

Return Gas

Evaporator S

Compressor

Total Subco

Product Information

Annual Energy Analysis

CO₂ Booster System

Tools

Operating Envelope

Operating Envelope: ZF54K5E-TFC (HFO-448A)

● Rating Point

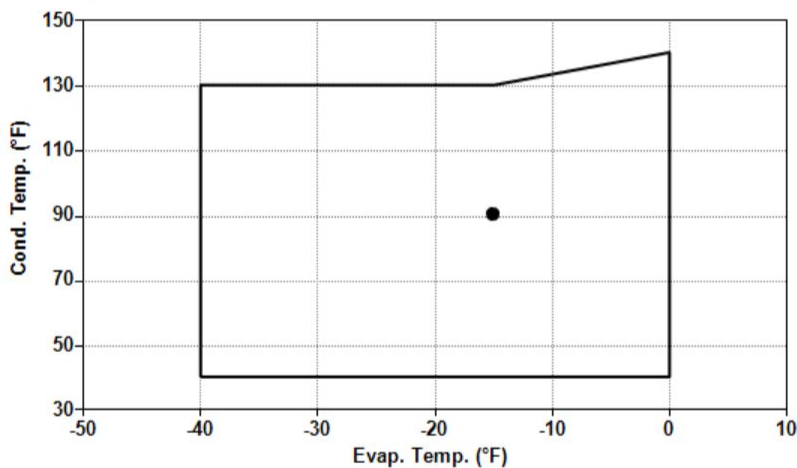

Rating Ref. No.: 17-618

Report

Close

Retain User Settings

Parts

Matrix

Current

Section

Ventilation Air

Coefficients

Close

Main Menu ::

Product Information

Compressors

Product Information

Annual Energy Analysis

CO₂ Booster System

Tools

April 11, 2023

Compressor Capacity Selection Method System Report R-448A, 208-230V, 3 Ph, 60Hz

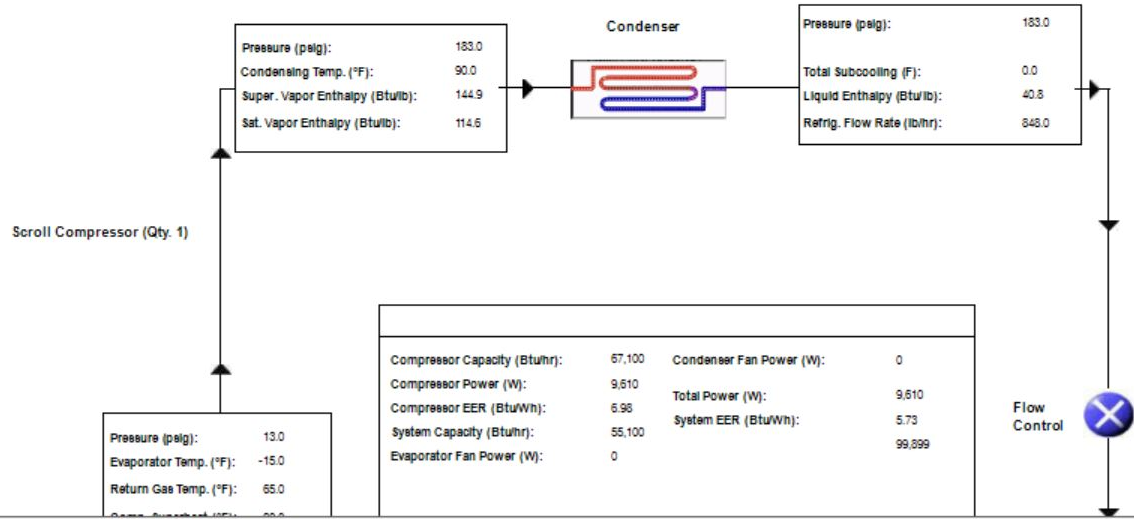

Main Menu ::

Product Information

Compressors

Search Box - Compressors

Search By Model Search By Condition

Search Criteria

Application: Voltage:

Refrigerant: Phase:

Temp. Range: Frequency:

Product Type: Modulation:

Availability: Model:

Exclude Obsolete Models

Compressor Capacity (Btu/hr) + % - %

Capacity Selection
 Compressor
 Evaporator

Conditions
 Temperature Pressure
 Dew Point Mid Point

Evap. Temp. (°F):
 Condensing Temperature (°F):
 Return Gas Temp. (°F):
 Total Subcooling (F):
 Evap. Superheat (°F):

System Fans

Parameters

Economizer Settings

Temp. Range Info.

Definitions

Search

Reset

Search By: Condition

Results

Select	Model	Refrig.	HP	Compressor Capacity (Btu/hr)	Compressor EER (Btu/Wh)	Evaporator Capacity (Btu/hr)	Evaporator EER (Btu/Wh)	Refrigerant Flow Rate (lb/hr)	Power (W)	Isentropic Efficiency (%)	Return Gas Temp. (°F)	Compress Superhea (°F)
<input type="checkbox"/>	4DB3R20ME-TSK	R-404A	13.50	112,000	7.72	89,000	6.14	1,968	14,500	68.8	65.0	65.0
<input type="checkbox"/>	4DB3R20ME-TSK	R-507	13.50	116,000	7.79	91,500	6.14	2,095	14,900	69.8	65.0	65.0
<input type="checkbox"/>	4DB3R20ML-TSK	R-404A	13.50	112,000	7.72	89,000	6.14	1,968	14,500	68.8	65.0	65.0
<input type="checkbox"/>	4DB3R20ML-TSK	R-507	13.50	116,000	7.79	91,500	6.14	2,095	14,900	69.8	65.0	65.0

Select All | 1 of 198 | Ready | Reset | Print

Note: Right mouse click selected compressor from list to view: Specific Point or Full Matrix Performance, Operating Envelope, Export Coeffs., Estimate Electrical Current, Cond. Heat Rejection, Drawing, Wiring Diagram, BOM, System Report & Mech. Room Ventil. Air.

Close

Main Menu ::

Booster System

CO₂ Booster System

Design Criteria

Frequency: 60

Voltage - Phase (Low. Temp.): 460-3

Voltage - Phase (Med. Temp.): 460-3

Med. Temp. Comp. Oil: POE Oil

Refrigerant: R-744

Low Temperature

Design Evap. Load (Btu/hr): 67,000

Evaporator Temp. (°F): -22.0

Evaporator Superheat (°F): 10.0

Non-Useful Superheat (°F): 26.0

Heat Reclaim : Pre-Heat Domestic Water

Parallel Compression

Medium Temperature

Design Evap. Load (Btu/hr): 201,000

Evaporator Temp. (°F): 15.0

Evaporator Superheat (°F): 10.0

Non-Useful Superheat (°F): 9.0

Gas Cooler Outlet Temp. (°F): 85.0

Flash Tank Pressure (Abs. bar): 40.0

Optimal Manual

Gas Cooler Pressure (psig): 1,018.4

Calculated Output

Med. Temp. Compressor Superheat (°F): 15.8

Low Temp. Return Gas Temp. (°F): 14.0

Med. Temp. Return Gas Temp. (°F): 30.8

Liquid Temp. (°F): 41.5

Bypass Flow Rate (lb/hr): 2,169.0

System EER (Btu/Wh): 6.66

Low Temp.: Compressor Selection

Compressor Model	Qty.	Rated Compressor Capacity (Btu/hr)	Evaporator Capacity (Btu/hr)	Power (W)	Refrigerant Flow Rate (lb/hr)	Compressor EER (Btu/Wh)	Current (Amps)	RLA (MCC/1.4) (Amps)	RLA (MCC/1.56) (Amps)	LRA (Amps)
4MSLS13ME-FSD	0	-	-	-	-	-	-	38.8	34.8	141.1
ZO21K5E-TFD	0	-	-	-	-	-	-	3.6	3.2	28.0
ZO34K3E-TFD	2	78,826	64,573	4,127	653.7	19.1	3.0	4.3	3.8	27.0
ZOD34K3E-TFD	0	-	-	-	-	-	-	4.3	3.8	27.0
Total:		78,826	64,573	4,127	653.7	Total Required Load (%):		96.4		

Medium Temp.: Compressor Selection

Compressor Model	Qty.	Compressor Capacity (Btu/hr)	Evaporator Capacity (Btu/hr)	Power (W)	Refrigerant Flow Rate (lb/hr)	Compressor EER (Btu/Wh)	Current (Amps)	RLA (MCC/1.4) (Amps)	RLA (MCC/1.56) (Amps)	LRA (Amps)
4MTLS82KE-FSD	0	-	-	-	-	-	-	28.3	25.4	141.1

Product Information

Annual Energy Analysis

CO₂ Booster System

Tools

:: Main Menu ::

Product Information

Compressors

Search By Model Search By Condition

Search Criteria
 Model: Refrigerant: Frequency: Temperature Range:

Exclude Obsolete Models Product Type: Modulation: Voltage Code: HP:

RLA (MCC/1.4) (Amps): RLA (MCC/1.56) (Amps): MCC (Amps): LRA (Amps): Status:

Settings

Default Setting Const. Return Gas Temp. (°F) Const. Compressor Superheat (°F)

Temperature Pressure Dew Point Mid Point

Retain User Settings

Inputs

Evaporator Temperature (°F):

Condensing Temperature (°F):

Return Gas Temperature (°F):

Evaporator Superheat (°F):

Compressor Superheat (°F):

Total Subcooling (F):

Results

Compressor Capacity (Btu/hr):

Net Refrigeration Effect (Btu/hr):

Power (W):

Compressor EER (Btu/Wh):

Evaporator EER (Btu/Wh):

Refrigerant Flow Rate (lb/hr):

Current (Amps):

Isentropic Efficiency (%):

Liquid Temp. (°F):

Discharge Temp. (°F):

- Reports
- [Performance: Full Matrix](#)
 - [Operating Envelope](#)
 - [Reference Drawing](#)
 - [Wiring Diagram](#)
 - [System Report](#)
 - [Summary](#)
 - [Estimate Electrical Current](#)

System Fans

Evaporator (W):

Condenser (W):

- Product Information
- Annual Energy Analysis
- CO₂ Booster System
- Tools

Close



Thank You Very Much!